

# **Rapid Assessment of Drinking-water Quality**

A Handbook for Implementation

October 2012



## WHO Library Cataloguing-in-Publication Data

Rapid assessment of drinking-water quality: a handbook for implementation.

1. Drinking water - standards. 2. Water supply – standards. 3. Water quality. 4. Environmental monitoring. 5. Handbooks. I. World Health Organization. II. UNICEF.

ISBN 978 92 4 150468 3

(NLM classification: WA 675)

**© World Health Organization 2012**

All rights reserved. Publications of the World Health Organization are available on [the WHO web site \(www.who.int\)](http://www.who.int) or can be purchased from WHO Press, World Health Organization, 20 Avenue Appia, 1211 Geneva 27, Switzerland (tel.: +41 22 791 3264; fax: +41 22 791 4857; e-mail: [bookorders@who.int](mailto:bookorders@who.int)). Requests for permission to reproduce or translate WHO publications – whether for sale or for noncommercial distribution – should be addressed to WHO Press through the WHO web site ([http://www.who.int/about/licensing/copyright\\_form/en/index.html](http://www.who.int/about/licensing/copyright_form/en/index.html)).

The designations employed and the presentation of the material in this publication do not imply the expression of any opinion whatsoever on the part of the World Health Organization concerning the legal status of any country, territory, city or area or of its authorities, or concerning the delimitation of its frontiers or boundaries. Dotted lines on maps represent approximate border lines for which there may not yet be full agreement.

The mention of specific companies or of certain manufacturers' products does not imply that they are endorsed or recommended by the World Health Organization in preference to others of a similar nature that are not mentioned. Errors and omissions excepted, the names of proprietary products are distinguished by initial capital letters.

All reasonable precautions have been taken by the World Health Organization to verify the information contained in this publication. However, the published material is being distributed without warranty of any kind, either expressed or implied. The responsibility for the interpretation and use of the material lies with the reader. In no event shall the World Health Organization be liable for damages arising from its use.

## **Acknowledgements**

The World Health Organization wishes to acknowledge the efforts of the following people who contributed to this handbook from their knowledge and experience: the authors of the document Guy Howard (at the time: Loughborough University, now: Department for International Development, DFID, United Kingdom), Margaret Ince (Loughborough, United Kingdom), Oliver Schmoll (Federal Environment Agency, UBA, Germany) and Mike Smith (Loughborough University, United Kingdom). The process of developing and guiding this handbook was managed by Federico Properzi (at the time: WHO, now: UN-Water), Sam Godfrey (UNICEF), Jamie Bartram (at the time: WHO, now University of North Carolina at Chapel Hill, USA), Clarissa Brocklehurst (UNICEF until June 2011), Rifat Hossain and Robert Bos (WHO). WHO also acknowledges contributions from Ines Enning (Federal Environment Agency, UBA, Germany) for editorial support and the numerous valuable comments from the reviewers of this handbook, Cecilia Alexandre, Manuel Alvarinho, Fred Arnold, Mien Ling Chong, David Cunliffe, Joan Rose and Luis Simas, and from experts attending a consultation on sampling methods and procedures held in Geneva in June 2012, including Juan Munoz and David Megill – the latter two reviewed this handbook and suggested a way forward with respect to a future revised version this handbook.

## Foreword

The period of the Millennium Development Goals (MDG) is nearing its end with the target year, 2015, on the horizon. In the next decade we are likely to look back on the first fifteen years of the third Millennium as a remarkable period in terms of progress towards promoting people's access to drinking-water and sanitation. Indeed, the 2012 progress report of the WHO/UNICEF Joint Monitoring Programme on Water Supply and Sanitation (JMP) announced that the drinking-water target had been met in 2010: between 1990 and 2010 the proportion of people without access to "improved" sources of drinking-water had been more than halved.

The success story of the efforts to achieve the MDG drinking-water target has its roots in design: simplicity, a singular focus and a correct estimation of what is feasible, without losing ambition. The contrast with the sanitation target is striking: it is expected that over 2 billion people will remain without access to basic sanitation by 2015 – from the monitoring perspective this reflects a lack of estimating feasibility of the sanitation target at the time when it was added to the MDG framework, as an afterthought, in 2002.

While the simplicity of the drinking-water target clearly is a strength, it represents a weakness at the same time. There is a disconnect between the target –by 2015, to halve the proportion of people without sustainable access to safe drinking-water– and the indicator to measure progress –access to and use of "improved" drinking-water sources. From the start of MDG monitoring, the JMP team in WHO and UNICEF has been keenly aware of the fact that "improved" water sources, as technologies with a high level of probability to deliver safe and clean drinking-water, do not provide a foolproof perfect guarantee of its safety. The use of a technology-related proxy-indicator was and to this day continues to be the only way to monitor progress towards the target at a global level through household surveys and censuses.

RADWQ, the Rapid Assessment of Drinking-water Quality was conceived to probe into the question to what extent the quality of drinking-water from "improved" sources deviates from the assumption that it is safe. Not surprisingly, the results in five countries showed a wide range of conditions, from full compliance with the guideline values in the WHO Drinking-water Quality Guidelines, to specific sources in a given country only meeting standards in 34% of the samples.

The significance of RADWQ does not lie only in producing snapshot results that confirm our well-founded suspicions. What RADWQ triggered in the countries where it was implemented was an enhanced interest and political will to improve national water quality testing through new or strengthened regulatory frameworks, through allocation of resources to regulatory surveillance and audits, and through the adoption of the WHO-recommended approach of water safety planning. Further efforts along the lines of RADWQ will take global water quality testing out of the strict sphere of monitoring, surveys and statistics into the broader field of capacity development. And as countries' capacity to monitor drinking-water quality is progressively realized, contributions to a global monitoring system will increase and a clearer picture will emerge of where investments are needed to further expand people's access to truly safe drinking-water.

This handbook describes methods and procedures applied in the RADWQs carried out by WHO and UNICEF in five pilot countries – they can be adopted by any authority or institution that wants to prepare a snapshot of the quality of "improved" sources of drinking-water, as a first step towards strengthening drinking-water quality regulation. In the expectation that more sophisticated targets and indicators will become available after 2015, JMP has started the development of a second version of the handbook that puts the quality testing in a better defined household-based sampling framework. In the post-2015 transition period it is expected that the basic categories of "improved" and "unimproved" sources will give way to more precise indicators, but until the basic categories are fully phased out, there will be value in carrying out RADWQs as originally intended to put water quality higher on national political agendas.

Robert Bos  
Coordinator  
Water, Sanitation, Hygiene and Health  
WHO Geneva  
October 2012

## Table of contents

Acknowledgements.....	iii
Foreword.....	iv
List of tables.....	vii
List of figures.....	viii
List of boxes.....	viii
Abbreviations and acronyms.....	ix
1 DRINKING-WATER QUALITY AND HEALTH.....	1
1.1 Water access and safety.....	2
1.2 WHO's framework for safe drinking-water.....	3
2 RAPID ASSESSMENTS OF DRINKING-WATER QUALITY.....	5
2.1 Scope and benefits of rapid assessments.....	5
2.2 Indicator and parameter selection for basic/initial assessments.....	6
2.3 Roadmap to RADWQ planning and implementation.....	8
2.4 Link to monitoring programmes.....	10
3 ASSESSMENT SURVEY DESIGN.....	11
3.1 Defining a water supply as the basic sampling unit.....	12
3.1.1 Minimum population size.....	14
3.1.2 Zoning of piped water systems.....	14
3.1.3 Household water.....	15
3.2 Step 1: Calculating the sample size.....	15
3.2.1 Estimating the proportion.....	16
3.2.2 Design effect.....	18
3.2.3 Bias and precision.....	19
3.2.4 Summary of sample size calculation.....	19
3.3 Stratifying the sample size.....	19
3.3.1 Step 2: Primary stratification.....	20
3.3.2 Step 3: Secondary stratification.....	21
3.4 Step 4: Defining cluster size.....	22
3.5 Step 5: Defining and selecting sampling units.....	24
3.6 Step 6: Selecting clusters and water supplies.....	26
3.7 Summary of data requirements.....	27
3.8 Summary of survey design steps.....	28
3.9 Review of sampling issues for this handbook.....	30
4 FIELD IMPLEMENTATION.....	31
4.1 Establishment of teams for survey management and implementation.....	31
4.1.1 Inter-sectoral RADWQ management team.....	31
4.1.2 Field teams.....	32
4.2 Work plan development.....	33
4.2.1 Requirements.....	33
4.2.2 Drawing up the work plan.....	34
4.3 Preparation for field work.....	37
4.3.1 Training.....	37
4.3.2 Sample point selection within clusters.....	38
4.3.3 Sanitary inspections.....	40
4.3.4 Sample collection and storage.....	41
4.3.5 Practical planning issues.....	43
4.3.6 Recording the results.....	44

4.4	Analytical quality control.....	45
4.4.1	Microbial analysis.....	45
4.4.2	Physico-chemical analysis.....	47
5	MICROBIAL QUALITY MONITORING.....	49
5.1	Indicator selection for rapid assessments.....	49
5.2	Indicator bacteria.....	51
5.3	Critique of the indicator-based approach.....	52
5.4	Other parameters of significance to microbial quality.....	53
5.5	Analytical methods.....	54
5.6	Field and laboratory-based approaches.....	54
6	SANITARY INSPECTIONS.....	57
6.1	Sanitary inspection techniques and forms.....	57
6.2	Pollution risk appraisal.....	61
6.3	Visual inspection.....	61
6.4	Advantages, limitations and applications of techniques.....	61
6.5	Risk-priority matrix.....	62
6.6	Recommendation for RADWQ.....	63
7	CHEMICAL AND PHYSICAL QUALITY MONITORING.....	65
7.1	Impact of chemical contamination.....	65
7.2	Parameter selection for rapid assessments.....	66
7.3	Physical parameters.....	69
7.4	Chemical parameters.....	71
7.5	Equipment recommendations.....	75
8	DATA MANAGEMENT, ANALYSIS AND USE.....	77
8.1	Data requirements.....	77
8.2	Data management.....	79
8.2.1	Data management team.....	79
8.2.2	Communication strategy during field implementation and data analysis.....	80
8.2.3	Obtaining a clean data set.....	81
8.3	Data analysis for basic/initial RADWQ surveys.....	82
8.3.1	Evaluation of water quality.....	83
8.3.2	Evaluation of sanitary integrity.....	85
8.3.3	Evaluation of household water quality.....	87
8.4	Additional uses of data analysis.....	88
8.4.1	Using data to assess operation and maintenance.....	88
8.4.2	Using data to identify the causes of microbial contamination in point sources.....	89
8.4.3	Using data to categorise systems.....	90
8.5	Use of data for developing remedial and preventative actions.....	90
8.5.1	Environmental interventions.....	91
8.5.2	Engineering interventions.....	91
8.5.3	Educational interventions.....	92
9	USING FINDINGS FROM RAPID ASSESSMENTS OF DRINKING-WATER QUALITY TO INFORM POLICY CHOICES.....	94
9.1	National overview.....	94
9.2	Water quality standards.....	95
9.3	Contextualising the results for policy makers.....	95
9.4	Identification of specific water quality mitigation options.....	96
9.5	Using rapid assessment data in other policy decisions.....	97
	ANNEXES.....	98

## List of tables

Table 2.1: Categories of “improved” and “unimproved” water sources (UNICEF and WHO, 2012) .....	6
Table 2.2: Indicators/parameters for basic/initial RADWQ .....	8
Table 3.1: Distribution system zones as water supplies.....	15
Table 3.2: Suggested range of water supplies that can be visited by one field team in one week.....	23
Table 3.3: RADWQ data requirements.....	28
Table 5.1: Examples of pathogens transmitted through drinking-water (modified from WHO, 2011a) .....	50
Table 6.1: A comparison of analytical and observation techniques for assessing water quality .....	62
Table 6.2: Example risk-priority matrix (WHO, 2011a) .....	63
Table 7.1: Summary of core and optional parameters for basic/initial RADWQ.....	67
Table 8.1: Raw data and data analysis requirements .....	77
Table 8.2: Compliance for thermotolerant coliforms by technology type for broad areas and nationally in Ethiopia (Tadesse <i>et al.</i> , 2010) .....	83
Table 8.3: Compliance for turbidity by technology type for broad areas and nationally in Nigeria (Ince <i>et al.</i> , 2010) .....	84
Table 8.4: Compliance for fluoride by technology type for broad areas and nationally in Ethiopia (Tadesse <i>et al.</i> , 2010) .....	84
Table 8.5: Overall compliance for thermotolerant coliforms, arsenic, fluoride and nitrate in Nigeria (Ince <i>et al.</i> , 2010).....	85
Table 8.6: Summary of compliance with WHO guideline values and national standards by parameter in Ethiopia (Tadesse <i>et al.</i> , 2010) .....	85
Table 8.7: Risk-priority matrix, nationally in Ethiopia (modified from Tadesse <i>et al.</i> , 2010).....	86
Table 8.8: Overall risk-priority classification, nationally in Ethiopia (modified from Tadesse <i>et al.</i> , 2010) .....	86
Table 8.9: Summary of sanitary risk inspection data for mechanised boreholes in Nigeria, nationally (Ince <i>et al.</i> , 2010).....	87
Table 8.10: Compliance for thermotolerant coliforms in household water in Ethiopia (Tadesse <i>et al.</i> , 2010) .....	87
Table 8.11: Comparison of thermotolerant coliform counts between household and source water in Ethiopia (Tadesse <i>et al.</i> , 2010).....	88
Table 8.12: Overall risk-priority classification for household water quality in Ethiopia (modified from Tadesse <i>et al.</i> , 2010).....	88
Table 8.13: Combined sanitary inspection and water quality data analysis for protected springs .....	90

## List of figures

Figure 2.1: Roadmap to RADWQ planning and implementation.....	9
Figure 3.1: Overview of the survey design process .....	12
Figure 4.1: Order of testing in RADWQ pilot studies .....	44
Figure 6.1: Example of pictorial sanitary inspection form for a protected spring .....	58

## List of boxes

Box 3.1: Worked example – Primary stratification .....	20
Box 3.2: Worked example – Secondary stratification .....	22
Box 3.3: Worked example – Cluster size definition and cluster calculation .....	23
Box 3.4: Worked example – Definition and selection of sampling units .....	25
Box 3.5: Worked example – Selection of cluster and water supplies.....	27
Box 4.4: Worked example - Allocation of household sampling points .....	40
Box 4.5: Taking samples.....	42
Box 4.6: Examples of checklists for field implementation teams.....	43
Box 4.7: Identification code used in RADWQ pilot studies.....	45
Box 4.8: Worked example – Quality control for microbial analysis .....	47
Box 4.9: Worked example – Quality control for chemical analysis .....	48
Box 6.1: Example of sanitary inspection form for a protected spring .....	59
Box 6.2: Example of the value of training from the RADWQ pilot.....	60
Box 8.1: Worked example – Cleaning the data set .....	81
Box 9.1: Response plans to RADWQ in India.....	96
Box 9.2: RADWQ for technology selection in Bangladesh .....	96



## Abbreviations and acronyms

ANOVA	Analysis of variance
As	Arsenic
BA	Broad area
CI	Confidence interval
D	Design effect
DHS	Demographic and Health Surveys
E	Acceptable precision
<i>E. coli</i>	<i>Escherichia coli</i>
F	Fluoride
Fe	Iron
GV	Guidelines value (from WHO Guidelines for Drinking-Water Quality)
JMP	Joint Monitoring Programme for Water Supply and Sanitation
MDG	Millennium Development Goal
MICS	Multiple Indicator Cluster Survey
MPN	Most probable number
N	Required number of samples (sample size)
N	Total number of clusters required
NH <sub>3</sub>	Ammonia
NH <sub>4</sub> <sup>+</sup>	Ammonium
NO <sub>3</sub>	Nitrate
NTU	Nephelometric turbidity units
P	Proportion
pH	Potential hydrogen ion concentration
RADWQ	Rapid assessment of drinking-water quality
ROS	Republic Osmiga
SI	Sampling interval
SIRS	Sanitary inspection risk score
SR	Service reservoir
Tc	Cumulated number for total supplies in broad area
TCU	True colour units
TDS	Total dissolved solids
TNTC	Too numerous to count
TTC	Thermotolerant coliforms
UNICEF	United Nations Children's Fund
WHO	World Health Organization
WSP	Water safety plan
WSS	Water supply scheme
WTW	Water treatment works



# 1 DRINKING-WATER QUALITY AND HEALTH

Water has a profound effect on human health both as a means to reduce disease and as a medium through which disease-causing agents may be transmitted. The impact of water on health derives principally from the consumption of water containing pathogenic organisms or toxic chemicals and the use of inadequate volumes of water that lead to poor personal and domestic hygiene.

The risk of acquiring a waterborne infection increases with the level of contamination by pathogenic micro-organisms. However, the relationship is not simple and depends on factors such as infectious dose and host susceptibility. Drinking-water is only one way for the transmission of such pathogens; some agents may be transmitted from person to person, or through the consumption of contaminated food. In many cases, poor personal hygiene may lead to the transmission of pathogenic organisms through contamination of water stored within the home or during preparation of food. Poor hygiene practices may result from the use of inadequate volumes of water and therefore water quantity is also important in controlling infectious diarrhoeal diseases. The effect of the use of soap in reducing diarrhoea is also well documented.

Safe excreta disposal is also critical as a first barrier to disease transmission. Therefore, the reduction of morbidity and mortality from infectious diarrhoeal diseases requires improvements in the quality and availability of water, excreta disposal and general personal and environmental hygiene. Different aspects of environmental health improvement may be critical in different circumstances and will be determined by the current health burden, economic development and availability of services, as well as nutritional and immune-status.

Water quality control is critical in reducing the potential for explosive epidemics, as a contaminated water supply<sup>1</sup> provides one of the most effective pathways for mass transmission of pathogens to a large population. However, water quality may not be more important than other aspects in controlling endemic disease. Different interventions may yield the greatest impact in different communities and at different times within the same community but water quality will always be important.

Links between chemical quality and health are also well-known. Naturally-occurring chemicals in water are seldom acutely dangerous to health, although nitrates in water may present a serious health risk to young infants (aged less than 6 months). Other naturally-occurring chemicals (such as fluoride and arsenic) can cause chronic health problems, when ingested over a long period. Certain chemicals, such as iron or manganese, which may be present in water, are likely to affect the acceptability of water for drinking, but have limited direct health significance. Such chemicals may affect the taste of water, and can cause staining of food (during cooking) and clothing (when washed), factors which may lead to consumers rejecting the water source for one that does not have these properties but may actually be more hazardous to health. Chemicals produced by human activities, mainly agricultural and industrial, are also known to contaminate water and present health risks (e.g. pesticides and heavy metals): such occurrences are usually location-specific and should be identified by sanitary and environmental risk assessments.

It is important for human health that all water destined for drinking should be of good quality from the point of supply up to the point of consumption. Quality is normally assessed against both microbial indicators and chemical parameters, although the microbial quality is the most important aspect from a public health perspective, because onset of illness (and possibly epidemic outbreaks) caused by some pathogenic organisms can be very fast. Water from some sources, primarily

---

<sup>1</sup> Water supply in this handbook is generally referred to as an “improved” source of drinking-water.

groundwater, tends to be of good quality and will need little treatment; water from other sources, primarily surface water, may be unsuitable for domestic use unless it first receives treatment to improve its quality. Water treatment is often impractical in rural areas, as it usually requires skilled supervision and can be very expensive. It is therefore preferable to select sources that can be protected against contamination. Some water sources such as boreholes and rainwater, should be free from microbial contamination, provided that adequate precautions are taken to prevent the water from coming into contact with any contaminants.

The majority of the world's population does not have access to continuously flowing water piped into their homes and must carry, transport and store water within their homes. In these situations, recontamination of drinking-water is often significant and is increasingly recognised as an important public health issue. Assessing the quality of water is therefore important within households as well as in sources and piped supplies.

Some water sources may be considered unsuitable by individuals or communities on the basis of personal or local preferences. The taste, odour and appearance of water must normally all be considered good for water to be acceptable for local consumption. Perceptions about water quality, based on visual examination, taste and odour, are often unreliable. Waters that look or smell unpleasant may be safe to drink, and clear odourless waters may contain chemicals or microbial contaminants that are harmful to human health. Objective techniques for the assessment of water quality are therefore necessary. These may be performed using widely available analytical techniques and supported by a range of risk assessment tools. These are described further below.

### ***1.1 Water access and safety***

The provision of water was one of the eight components of primary health care identified by the International Conference on Primary Health Care, Alma-Ata, in 1978. The Declaration of Alma-Ata expanded the concept of health care to include broader concepts of affordability, accessibility, self-reliance, inter-sectoral collaboration, community participation, sustainability and social justice.

The importance of water supply continues to be emphasised as critical to reducing poverty and improving the health and well-being of the world's children and adults. The global community committed itself, by adopting the Millennium Development Goals (MDG), to halving the proportion of people without sustainable access to safe drinking-water and basic sanitation, by 2015. Although great strides have been made in meeting this challenge in terms of provision of services, the safety of many water supplies remains unknown and uncertain. The United Nations Children's Fund (UNICEF) and World Health Organization (WHO) Joint Monitoring Programme for Water Supply and Sanitation (JMP) reports biennially on progress towards achieving this target, based on statistics regarding access to technologies that are either "improved" or "unimproved" (UNICEF and WHO, 2012). This categorisation was made on the assumption that "improved" technologies, because of their design and/or quality of construction adequately protect the source from outside contamination, in particular with faecal matter, and thus likely to provide water of better quality and reduce public health risks, although it was recognised that this would not always be the case (UNICEF and WHO, 2012). However, currently the JMP assessments do not provide information on actual drinking-water quality.

There is significant value in the reporting of independently verifiable data on both water quality and the integrity and efficiency of abstraction works, water treatment, distribution, storage and/or household management to support national governments and the international community in measuring progress in achieving the international development targets. Such data provide useful information regarding current conditions, deriving the likely public health burden related to inadequate water supply and providing an understanding of the extent of major water quality

challenges in countries. These data would, therefore, inform decisions on future investment priorities and needs at a national, regional and global level.

This handbook is designed to help in the implementation of rapid assessment of drinking-water quality (RADWQ) to improve the knowledge and understanding of the level of safety of water supplies defined as coming from “improved” sources and, hence, to support development of understanding of the proportion of water supply technologies that deliver safe drinking-water. The concept of RADWQ and a roadmap for its implementation are introduced in Chapter 2.

## ***1.2 WHO’s framework for safe drinking-water***

The continuous delivery of safe drinking-water requires effective management and operation throughout the drinking-water supply chain from the catchment and source through to the point of consumption, within national, regional and local contexts. The WHO Guidelines for Drinking-Water Quality suggest that this is most effectively achieved by establishing a preventative management framework for safe drinking-water that encompasses the following elements (WHO, 2011a):

- establishment of health-based targets, including water quality targets, for drinking-water as a “benchmark” for evaluation of the adequacy of existing installations and policies;
- in order to meet these targets, the development and implementation of water safety plans (WSP). WSP provide a quality management system for water suppliers at different scales, which is based on principles of risk assessment and risk management, and which aims at continuous management and control of water sources, treatment, distribution, handling and storage together with documented management, actions and communication plans;
- establishment of a system of independent surveillance that verifies that WSP are working effectively and that health-based targets are met.

The use of RADWQ tools, methods and procedures can contribute to the implementation of the framework principles. For example, they provide useful baseline information on drinking-water quality in a given region or country that can be utilised for national target setting or for prioritizing surveillance efforts.



## 2 RAPID ASSESSMENTS OF DRINKING-WATER QUALITY

Routine (iterative, regular and frequent) assessment of drinking-water quality is undertaken to provide data and information for many reasons, including:

- determination of the overall background and trends in quality;
- monitoring compliance with regulations, guidelines, targets and/or standards;
- identification of water quality or pollution problems and issues;
- planning and development of remedial actions; and
- informing policy decisions on issues such as water source and technology development, revision of regulations for drinking-water quality or effluent discharge consents.

In addition, specific (non-routine) assessments may be instigated in response to issues such as the need to identify the source(s) of an outbreak of a water-related disease, management of an acute agricultural/industrial pollution incident or concerns relating to a particular parameter (e.g. arsenic in groundwater).

Rapid assessment of drinking-water quality (RADWQ), as described in this handbook, is an example of a specific assessment. RADWQ uses intensive field work to collect one-off water quality and sanitary inspection data focused on the category of “improved” water sources as defined by JMP, applying a sampling approach that results in a nationally representative dataset. Data analysis creates a snapshot of the level of correlation between the designation “improved” of a source and the quality of the drinking-water it provides in reality. As such, RADWQ is a ground-truthing exercise to enhance our knowledge and understanding of the water quality situation in a snapshot fashion in a specific setting against the assumptions supporting the JMP definition of “improved” sources.

### 2.1 *Scope and benefits of rapid assessments*

The RADWQ methodology described in subsequent chapters has primarily been developed to complement global assessments under the JMP (UNICEF and WHO, 2012) and hence aims to assess the extent to which “improved” sources, as defined in the JMP assessments of global water and sanitation provision (see Table 2.1) actually provide safe drinking-water within a country, and to compare water quality and sanitary conditions of the “improved” sources. Water obtained from an “improved” source may not be safe to drink. Reasons why “improved” sources may not provide safe drinking-water may include extensive microbial contamination undetected because of limited monitoring, the presence of elevated levels of naturally occurring chemicals, inadequate treatment in relation to source water quality, poor maintenance and/or operation of the supply, and short-term contamination events which have been shown to be important causes of outbreaks (Hunter *et al.*, 2009).

However, the RADWQ methods and procedures may also be used by national regulators or surveillance agencies for a variety of targeted water quality assessments and as the basis for developing an effective approach to routine water quality surveillance; as such, it can be used to

- obtain baseline information through a systematic “snapshot” of drinking-water quality in a given country or at any sub-national level (e.g. rural areas);
- assess the prevalence of a specific parameter (e.g. arsenic or fluoride);
- check compliance for a particular type of water supply (e.g. point sources) or in households;
- investigate seasonal changes in drinking-water quality;
- investigate an emergency recovery phase.

**Table 2.1: Categories of “improved” and “unimproved” water sources (UNICEF and WHO, 2012)**

JMP category	Supply technology
“Improved”	Piped water into dwelling, yard or plot Public tap or standpipe Tubewell or borehole Protected spring Protected dug well Rainwater collection
“Unimproved”	Unprotected dug well Unprotected spring Cart with small tank or drum Tanker truck Surface water (river, dam, lake, pond, stream, canal, irrigation channel) Bottled water *

\* Bottled water is considered to be “improved” only when the household uses drinking-water from an “improved” source for cooking and personal hygiene.

Some of the key reported benefits of rapid assessments include:

- thorough compilation (from various institutions) and review of already existing data on drinking-water quality and water supply coverage in a country, as well as identification of data or information gaps;
- creation of a national data base on drinking-water quality and sanitary conditions which provides solid baseline information for the establishment (or stepwise improvement) of routine water quality monitoring and surveillance programmes, and/or for targeting resources and efforts in surveillance and/or remediation programmes;
- capacity building in water quality monitoring and assessment, including policy formulation, strengthening institutions, facilitating networking between national, regional and local institutions and development of the human resource base; and
- raised public awareness of the importance of drinking-water quality and health issues in populations visited during the assessment.

## ***2.2 Indicator and parameter selection for basic/initial assessments***

The selection of indicators and parameters for a programme of water quality assessment and analysis is likely to be country- (and possibly region-) specific and may also be specific to certain sources of water. Furthermore, the range of analysis and frequency of testing will be constrained by the resources available for water quality sampling and analysis and, whilst it may be desirable that a great number of indicators and parameters are analysed frequently, budget constraints may restrict the frequency of sampling and testing, or the number of indicators/parameters to be analysed. In general, however, there are some basic rules that should guide the development of water quality assessment programmes.

The first step in deciding whether a particular indicator/parameter should be included in the assessment programme is to make a judgement on the following critical questions:

- Is the contaminant or substance known to be present or absent in the waters of the country? If known to be present or if no information is available, then the indicator/parameter should be included. If it is known to be absent, then it should be excluded.
- If known to be present, at what concentration does the contaminant exist and does the concentration approach or reach levels which are of public health concern?
- What is the extent (temporal and spatial) of the presence of the contaminants?



- Are there any current or planned activities in catchment areas that may cause the contaminant to be present in water or levels to increase?

There is a tendency with authorities in some countries to place undue emphasis on contaminants with a limited or unproven risk to health whose detection may require sophisticated and expensive analyses. An example is the current concern over perceived risks of minute concentrations of pharmaceutical and personal care products, and their residues, in drinking-water. Emphasizing the measurement of such contaminants may be at the expense of effectively monitoring key indicators relating to microbial quality and can be counter-productive in terms of reducing health risks.

The selection of indicators and parameters for inclusion in RADWQ is based on prioritising those that will have the greatest impact on the health status of the entire population, especially the most vulnerable groups (e.g. children, the poor, pregnant women).

In terms of priority the indicators/parameters to be included in water quality assessment and monitoring programmes can be summarised as follows:

1. microbial quality: micro-organisms which indicate faecal contamination (“indicator organisms” such as *Escherichia coli* or, as a surrogate, thermotolerant coliforms) and thus signal the potential presence in water of micro-organisms that are harmful to health (pathogens);
2. parameters that have been shown to influence microbial quality (such as disinfectant residuals, pH and turbidity);
3. chemical parameters of known health risk; and
4. aesthetic parameters, i.e. those that cause rejection of water (notably turbidity, taste, colour, odour, iron and manganese).

Resources and assessment capacity vary greatly in countries wishing to undertake rapid assessments. This handbook focuses on a set of core indicators/parameters (as shown in Table 2.2) that should be included in all basic/initial assessments, and selected examples of optional ones. In undertaking a rapid assessment it will be important to consider whether the chemical parameters included in the core parameters are present. For instance, arsenic is only likely to be present where it is naturally occurring, being derived from dissolution of arsenic-bearing minerals, or where there are mining operations or mine waste dumps that will leach arsenic. More details on individual parameters suggested and reasons for their inclusion in basic/initial assessments are provided in Chapters 5, 6 and 7. Revision of the list of core indicators/parameters should be considered if the proposed method will be used to investigate a specific concern, such as the risk associated with a particular type of supply (e.g. shallow well water), a particular parameter/group of parameters (e.g. metals) or a particular human activity (e.g. intensive agriculture).

The rapid assessment approach is sufficiently flexible to accommodate more sophisticated assessments that countries may wish to undertake either immediately or in the future. Additional indicators and parameters (for example, faecal streptococci, bacteriophages or pathogen assessments; assessments of organic compounds such as pesticides or disinfection by-products; or further inorganic parameters) can be included incrementally as technical, financial, human or institutional resources become available for higher levels of assessments.

**Table 2.2: Indicators/parameters for basic/initial RADWQ**

Parameters	Microbial and related	Inspections and risk assessments	Physical and chemical
Core set	Thermotolerant coliforms (TTC) Turbidity pH Chlorine residuals <sup>2</sup>	Sanitary inspection	Colour or appearance Odour <sup>3</sup> Conductivity Nitrate Arsenic <sup>4</sup> Fluoride <sup>4</sup> Iron <sup>4</sup>
Optional <sup>1</sup>		Brief interviews at treatment works Pollution risk assessments	Ammonia Metals other than iron <sup>5</sup> (e.g. aluminium, copper, lead, manganese)

1 Add indicators/parameters if known to be present and at levels causing concern; it may not be necessary to measure them at every location.

2 Chlorinated supplies only.

3 Subjective assessment but can be a good indicator of pollution.

4 Omit indicators/parameters if known to be absent but include if known to be present at levels causing public health concern or no information available.

5 Most are not easy to measure accurately using field equipment but as they do not deteriorate with time samples can be collected and analysed in a laboratory.

### **2.3 Roadmap to RADWQ planning and implementation**

This handbook describes a method of rapid assessment of drinking-water quality that is nationally representative, how it can be implemented and how the data it generates can be analysed. It provides details on how surveys can be designed (Chapter 3) and reviews the indicators of interest, describes how these may be analysed and how water supplies should be inspected (Chapters 5-7). It also provides information on how to plan and implement RADWQ in the field (Chapter 4) and on the analysis and reporting of data (Chapter 8).

A roadmap that illustrates the steps and processes to be followed in planning, designing and undertaking RADWQ is summarised in Figure 2.1. The roadmap refers to individual handbook chapters which provide details and support individual aspects of the survey:

- Chapter 3 provides details on how surveys can be designed and what data they require;
- Chapter 4 addresses practical planning and implementation of RADWQ in the field, including institutional, personnel and capacity building aspects;
- Chapters 5 and 6 review microbial indicators and chemical parameters of interest for inclusion in RADWQ and describe how these may be analysed; both chapters technically support defining the scope of the study and the process of indicator/parameter selection;
- Chapter 7 provides details on how sanitary inspection techniques can be employed in RADWQ;
- Chapter 8 provides information on data requirements as well as on management, analysis and reporting of data;
- Chapter 9 addresses how the RADWQ findings can be used to inform policy choices.

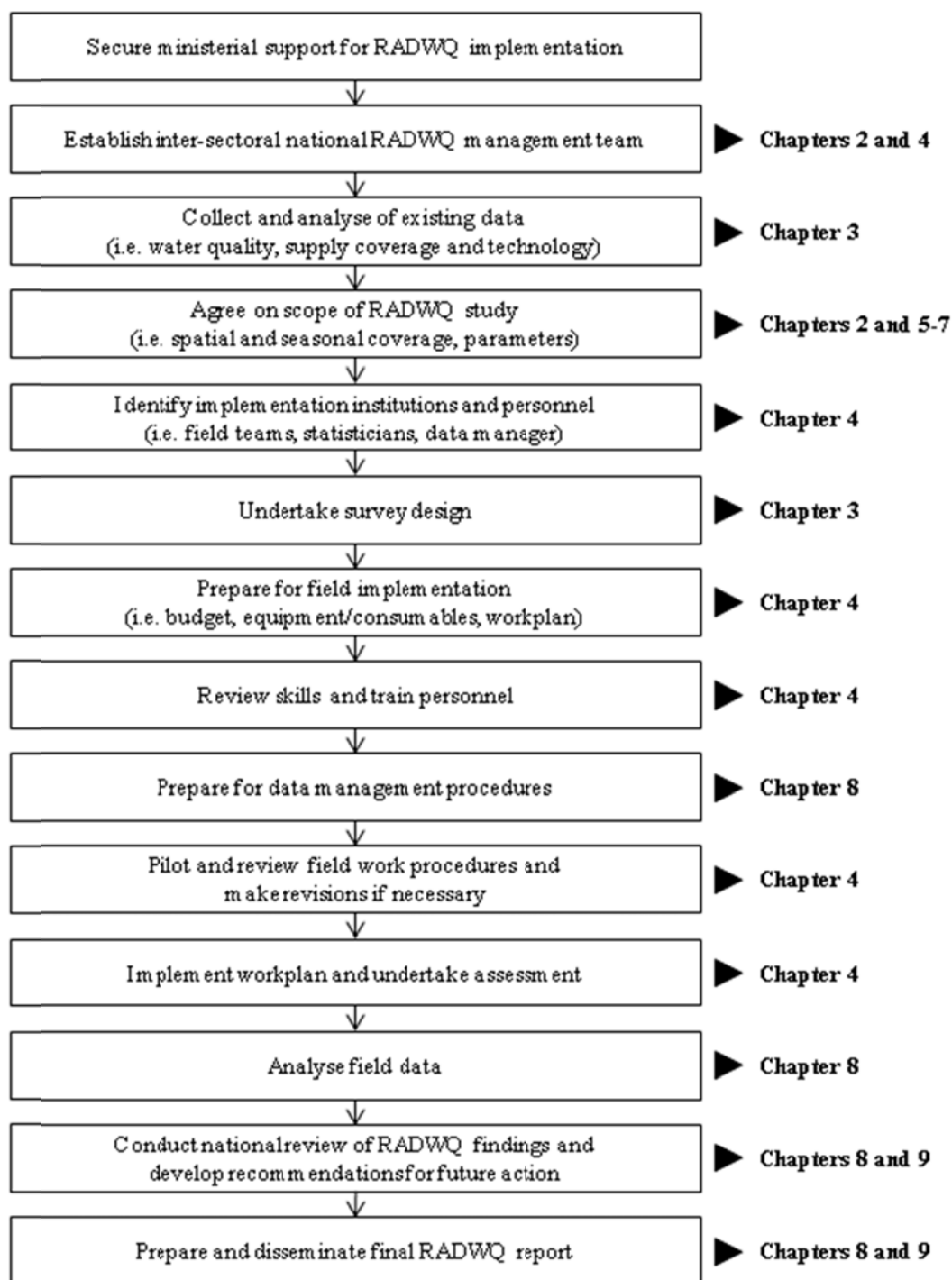

**Figure 2.1: Roadmap to RADWQ planning and implementation**

Successful implementation of rapid assessments will depend on sufficient institutional support from various public sectors such as public health, environment or water management, but also from those responsible for managing water supplies, be it utilities or communities. Thus, it is vital to establish good partnerships between institutions at various administrative levels (i.e. national, regional and local) and to make sure that all parties involved understand the methods and procedures, the added value of rapid assessments and their specific roles and responsibilities in this connection.

The establishment of an inter-sectoral RADWQ management team is a first, essential step in the implementation of a rapid assessment of drinking-water quality. This team should be coordinated by

a senior staff member from the Ministry of Health, the Ministry of Water or the Ministry of the Environment. The composition and coordination arrangements of this team depend on national organizational and regulatory structures, on roles and responsibilities with respect to drinking-water quality monitoring and surveillance, and on the specific objectives of the assessment. The team coordinator is responsible and accountable for the management, coordination and quality of the rapid assessment. The coordinator reports, on behalf of the team, to a broader group of national stakeholders. More details on the responsibilities of the RADWQ management team and criteria for its optimal composition are presented in Section 4.1.

#### **2.4 Link to monitoring programmes**

Although the rapid assessments described in this handbook will provide a nationally representative snapshot of the situation with respect to drinking-water quality, there remains a need to develop and implement effective ongoing routine water quality monitoring and surveillance programmes. The value of routinely collected data in assessing water safety, and in planning and prioritising interventions is profound. The survey methodology outlined in this text will also be appropriate to some such programmes, although other approaches exist as well.

It is strongly recommended that co-ordinators of an assessment consult Volume 3 of the 2nd edition of the WHO Guidelines for Drinking-water Quality, “Surveillance and control of community supplies” (WHO, 1997); “Surveillance of drinking water quality in rural areas” (Lloyd and Helmer, 1991); “Water supply surveillance: a reference manual” and “Water quality surveillance: a practical guide” (Howard, 2002a; 2002b); “Water safety plan manual: step-by-step risk management for drinking-water suppliers” (Bartram *et al.*, 2009); “Chemical safety of drinking-water: assessing priorities for risk management” (Thompson *et al.*, 2007); the “UNICEF handbook on water quality” (UNICEF, 2008); and “Water safety planning for small community water supplies: Step-by-step risk management guidance for drinking-water supplies in small communities” (WHO, 2012) for more details.

### 3 ASSESSMENT SURVEY DESIGN

This Chapter deals with the recommended survey design procedures for the implementation of a rapid assessment of drinking-water quality that focuses on testing whether “improved” sources of drinking-water, as defined by the WHO/UNICEF Joint Monitoring Programme on Water Supply and Sanitation (JMP), meet some of the key guideline values, as proposed by the WHO Guidelines for Drinking-water Quality (2011a). This handbook does not discuss in detail the purposes of sampling and the range of possible approaches to survey design. The bibliography in Annex 1 includes references to appropriate texts on sampling and statistics (such as UNICEF, 1995; Helsel and Hirsch, 1992). The sampling issues related to rapid assessments of drinking-water quality went through a thorough review by sampling statisticians and their preliminary observations are presented in section 3.9. This present version of the handbook aims at establishing an indication to what extent the different types of “improved” drinking-water sources match or do not match the WHO guideline values referred to above..

The survey design proposed here for a rapid assessment of drinking-water quality uses a cluster sampling approach for the selection of the water supplies to be included in the assessment. Cluster sampling means that the water supplies selected for inclusion in the assessment are located geographically close to one another (i.e. in “clusters”). The purpose of cluster sampling is to ensure that a representative sample of all water supply technology types in a country is obtained, whilst ensuring efficiency and reducing cost of the survey. In employing a cluster sampling approach, however, it is critical to ensure the clusters selected as a whole are representative of the country (or particular issue). Thus, for example, clusters all located within one region of a country are unlikely to be representative.

In cluster survey techniques, the study population is stratified into a number of small, mutually exclusive groups (i.e. members of one group cannot simultaneously be members of another group). Each group is referred to as a cluster. When determining sampling sites, clusters are randomly selected, meaning that water will be tested in some clusters but not in others. This is different from stratified sampling, for instance, where water supplies from each strata would be tested.

Cluster sampling approaches are widely used in social sciences and in major international data collection exercises, such as the Multiple Indicator Cluster Surveys (MICS) and Demographic and Health Surveys (DHS), which contribute to the WHO/UNICEF JMP. They have had only a relatively limited use in the water sector to date outside the pilots undertaken as part of the development of this handbook and in studies in Bangladesh (Howard *et al.*, 2006a).

The basic sampling unit is the water source rather than the households that use them. These rapid assessments are primarily designed to assess the quality and sanitary conditions of drinking-water sources. It is recommended, however, to include limited testing of the quality of water stored in households and match this information to that on the quality of the water sources accessed as this provides valuable additional data (see section 3.1.3).

The key elements of the survey design are to ensure that

- different parts of a country are adequately represented (geographical spread);
- the selection of water supply technologies to be included reflects their importance;
- in the selection of water sources, a random element is introduced; and
- the study is sufficiently practical as well as cost and time effective (e.g. in terms of minimising the amount of travel within a cluster).

The survey design (including the collection of data needed for the design) is one of the core responsibilities of the national RADWQ management team. The following sections outline the stages in designing the survey and these are summarized in Figure 3.1 below.

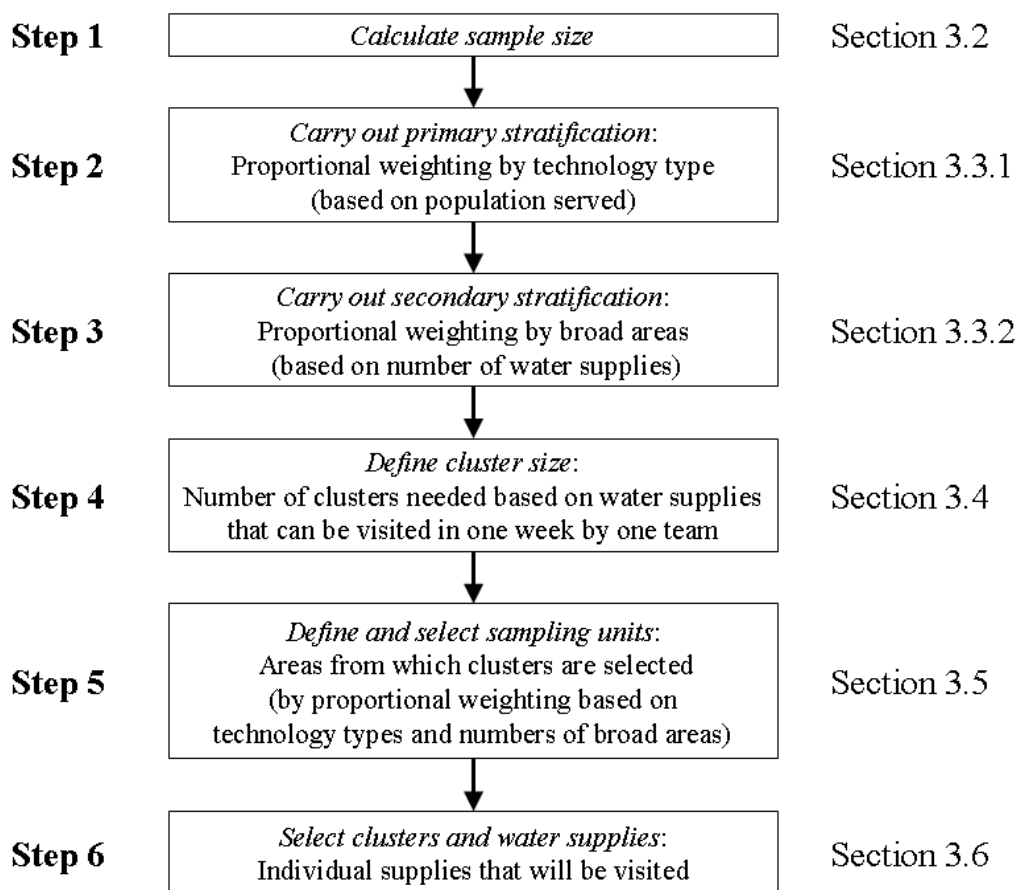

**Figure 3.1: Overview of the survey design process**

### **3.1 Defining a water supply as the basic sampling unit**

In RADWQ “improved” sources of drinking-water (as defined by JMP, see Table 2.1 above) are the subject of the study and thus the sampling unit. It is important at this stage to be clear what is meant by “improved” sources of drinking-water within the context of this assessment. An “improved” source of drinking-water is the means of delivery of domestic water to households. An “improved” source of drinking-water may be a point source (such as a single borehole or tubewell with handpump or a protected spring) or part of a reticulated, piped water system.

It is recommended that to be included as the basic sampling unit within the rapid assessment, an “improved” source of drinking-water (i.e. an “improved” water supply technology) should supply at least 5% of the national population. This threshold is selected as the point from where onwards the influence of the technology on overall “improved” sources of drinking-water and water quality will be significant. However, it is an arbitrary threshold and a higher (or lower) proportion could equally well be used. Technologies supplying less than this proportion can only be considered if they are particularly important in specific regions of the country, although it may be difficult to ensure representiveness.

“Improved” sources of drinking-water are considered the “target population”. However, within the rapid assessment there are two exceptions to this:

- It is recommended that rainwater collection is only included as a water source if there is reliable data showing that a sizeable proportion of the population (at least 5%) in a country rely on rainwater systems as their primary source of water. This is because in many cases rainwater supply is seasonal rather than a year-round source, and household frequently use other sources of water for some parts (at times the majority) of the year.
- It is also recommended that tanker services are included in the rapid assessment method as the quality of water may be as good as other forms of supply. Thus, it is recommended that only tanker services in urban areas (including peri-urban areas) where they are the principal form of supply to households (i.e. they are not used to supplement another water supply) should be included in the assessment. In addition, only tanker services that supply at least 5% of the population and that are fitted to vehicles or animal carts should be included in the assessment.

The list of technologies included within the rapid assessment is therefore as follows:

- Piped water system (irrespective of source)
- Borehole or tubewell
- Protected dug well
- Protected spring
- Tanker service (fitted to vehicles or animal carts)
- Rainwater system (where this is the primary supply)

For dug wells and springs, the specification “protected” refers to the existence of protection works that are designed to effectively prevent the source from direct contamination at the point of abstraction or resulting from rapid recharge pathways close to the source. For protected dug wells, designs usually include an apron surrounding the top of the well, a well cover and a hand pump or other sanitary means of water withdrawal from the well. For protected springs, designs typically include a retaining wall or spring box around the spring eye with an excavated area backfilled with loose material which is overlain by a protective cover. For further details on source protection measures refer to WHO (1997) and Howard *et al.* (2006b). In the context of rapid assessments it is important to note that different countries may use different sets of design criteria in order to define a “protected” source. In survey design, these criteria should be reviewed in order to define the boundaries between protected and unprotected technologies.

For the assessment, piped water systems typically can be sub-divided in relation to their management:

- *Utility water systems.* These are commonly piped water systems that are managed by an organisation that is distinct from the broader community which it serves. Examples include government water departments, corporations or utilities, local government (e.g. city, municipality, town or district councils) and private operators (of all sizes). This includes all small town systems operated by local government, even where the population numbers are relatively low.
- *Community managed water systems.* These are systems that are managed by the community which they serve. These include supplies with a water user association or group managing the supply, but only where all members are drawn from the community served. If the association has members drawn from outside the community, it represents a form of utility water system.

In the rapid assessment, countries may wish to study the possible differences in water quality of community managed and utility-piped water systems. If data available allow for such differentiation, the technology category “piped water systems” can be split into two sub-categories,

i.e. “utility managed” and “community managed”. In many countries, however, the data available may not allow such a differentiation.

### ***3.1.1 Minimum population size***

In order to simplify the rapid assessment procedure, the minimum population having access to an “improved” source of drinking-water should be defined at the outset in order to make the survey cost-effective. Only “improved” sources of drinking-water with this minimum size of population or greater should be included in the assessment. The testing of very small proportions of “improved” sources of drinking-water (one household or serving only a very few households) is expensive and their inclusion may not deliver a sufficient improvement in the quality of the data generated to justify the increased cost of the assessment.

The selection of a minimum community size depends in part on the distribution of settlement sizes in the country. A suggested range of minimum sizes is from 200 to 1,000 people, depending on the overall population size of the country. The figure of 200 reflects common design criteria for populations to be served by a single point water source, and 1000 may be appropriate for countries with very large populations, where community-management of “improved” sources of drinking-water extends to piped water supplies in larger villages and small towns. When establishing a minimum population, the figure selected and the reasons for this must be documented, and the estimated proportion of settlements that will be excluded should be calculated.

### ***3.1.2 Zoning of piped water systems***

In the context of the assessment, large piped water systems cannot be considered a single “improved” source, because their level of importance would not be reflected in a nationally representative way. In order to overcome this potential bias, large piped water systems are sub-divided into zones. Each zone is considered to be equivalent to an “improved” source of drinking-water.

Zones are primarily defined on the basis of the sources of water, treatment work and service reservoirs (tanks) that supply different parts of the distribution system. Zoning the water supply ensures that at any point within the distribution system the analyst knows the source or treatment works the water originates from and what major infrastructure it has passed through, all of which may have influenced quality. This information is essential when interpreting the results of water quality testing. Zoning approaches also usually set a maximum population for an individual zone to prevent certain types of water supply (for instance large urban systems with ring mains) having very few zones.

In this rapid assessment methodology a zone is equivalent to an “improved” source of drinking-water and its size should be sufficiently small to ensure that there are sufficient zones from which to select the sample. Within the WHO Guidelines for Drinking-water Quality (WHO, 2011a), it is recommended that one water sample is taken for analysis for every 5,000 population in systems serving up to 100,000 population. Thus, it is recommended that, for the rapid assessment, a population of 5,000 is taken to define one zone or (theoretical) supply.

Each part of the system served by a particular service reservoir or source should be sub-divided, therefore, into a number of zones, each having a population of up to 5,000. One sample of water will be taken for analysis from each zone selected for inclusion within the assessment. This approach to zoning of piped water systems is summarised in Table 3.1.



For example, a piped water supply that serves a population of 100,000 would be split into a minimum of 20 zones of up to 5,000 population (as described in Table 3.1). For the purposes of the rapid assessment survey design these 20 zones become 20 (theoretical) water supplies.

**Table 3.1: Distribution system zones as water supplies**

Supply characteristics	Zones based on system characteristics	Population criteria
Single source, single/no service reservoir (tank)	One zone	Max. zone size 5,000 population
Single source, multiple (more than one) service reservoirs (tanks)	Area served by each service reservoir is one zone	Max. zone size 5,000 population
More than one source with several service reservoirs (tanks)	For every source, each service reservoir is one zone	Max. zone size 5,000 population

In those countries with a small population and with a high piped water coverage it may happen that the actual number of existing “improved” sources of drinking-water (including piped water zones) is lower than the overall sample size for “improved” sources of drinking-water to be included in the assessment (see Section 3.2). In this case the survey design must be modified, i.e. by taking a population of 2,500 to define one zone or (theoretical) supply (see also example options given in Box 3.2).

### **3.1.3 Household water**

The quality of water stored in households will also be tested in the assessment to provide some indication of the scale of post-source contamination. Household water must be matched to source and therefore household water will only be tested in communities where an “improved” source of drinking-water is included in the assessment. Household samples are not part of the sample size (see Section 3.2), but are considered additional.

The selection of households is not based on statistical sampling. Households should not be selected in every community where a water supply is tested, but only in a sample of communities. For a basic/initial RADWQ it is recommended that the minimum number of household samples should be 10% of the overall sample size for “improved” sources of drinking-water. For example, if the overall sample size is calculated at 1,600 samples, a minimum of 160 additional samples needs to be taken from households. The selection of communities where household water testing will be carried out should reflect the overall distribution of technology types. Thus, if 12% of “improved” sources of drinking-water included in the assessment are boreholes/tubewells, then 12% of household water tests should be in communities served by boreholes/tubewells.

Depending on the resources available for other RADWQ programmes, a suggested maximum number of household samples is 50% of the overall sample size for water supplies - this is equivalent to taking samples from five randomly selected households in every tenth community where a water supply is selected. Where the sample size for “improved” sources of drinking-water (see Section 3.2) is small, it is useful to err towards the maximum number (50%) of households to be tested. Where the sample size is high, it is useful to err towards the minimum number (10%) of households to be tested.

## **3.2 Step 1: Calculating the sample size**

The number of samples of water to be taken in the rapid assessment (sample size) can be calculated using the Equation 3.1 below which is derived from UNICEF (2006):

**Equation 3.1:** 
$$n = \frac{4P(1-P)D}{e^2}$$

n	required number of samples (sample size)
P	assumed proportion of water supplies with a water quality exceeding the target established
D	design effect
e	acceptable precision (i.e. the level of accuracy required considering the variance of the estimated proportion)

### ***3.2.1 Estimating the proportion***

The first stage in calculating the sample size is to estimate the proportion (P) of the target population (in this case "improved" sources of drinking-water) that will meet some pre-set criteria, or in other words, the assumed proportion of such "improved" sources with a water quality exceeding a specific target, for instance the WHO guideline value (GV) or a national standard.

In general (at least with larger data sets) the estimation of a proportion follows a normal distribution. If the normal distribution is considered, when this is set at 0.5, this will maximise the likelihood of obtaining a sample that is representative of the central tendency of the data distribution and the standard deviation is likely to encompass the majority of the true value of the data. Therefore, if there is very limited data available to estimate the proportion, it is always safest to err towards P = 0.5, i.e. assuming that 50% of water supplies do not meet the water quality target as the worst case scenario. This also provides a conservative estimation of the required sample size (i.e. larger than required).

In many cluster surveys the sample size is calculated for each variable under consideration, and often the largest sample size calculated is used for the survey. In estimating the proportion it is important to define the criteria which the survey is attempting to measure. In the case of water quality assessments the criterion will be certain levels of contamination in water supply. For microbial quality, the measurement criterion should either be the absence of faecal indicator bacteria or a concentration below a specified level in a 100 ml sample. For chemical parameters, the measurement criterion should be based on the proportion of samples expected to exceed national standards and/or the WHO GV for the parameter. It is likely that chemical parameters, therefore, will have a proportion estimated below 0.5.

For RADWQ, the sample size needed for the microbial quality is almost certainly likely to be the greatest as the likelihood is that most water supplies will (at least at some time) show contamination. Therefore, the sample size can be calculated solely for the microbial quality, with some minor adjustments made for chemical contaminants.

In order to estimate the likely proportion of supplies showing contamination, two approaches can be adopted: an estimate based on expert judgement, or a calculation based on review of existing data as discussed below.

#### ***Using expert judgement***

In this approach, an informed guess must be made of the level of contamination. This may be done based on discussions with national drinking-water quality experts. If this approach is used then it is important to discuss with both field-based and managerial staff. Such approaches may be relatively reliable, particularly in situations where testing has been done but records have not been kept or are not accessible for analysis.

In trying to use this approach, the initial reaction of water quality experts may be that “many”, “most” or “very few” supplies are contaminated. This obviously creates difficulty as “many” could be anywhere between say 30% and 97% of water supplies. It is important to try and estimate an actual proportion that may be contaminated, although this may only be at relatively large intervals (e.g. at intervals of 10%).

When using expert judgement, it will probably be most effective to “pool” information about likelihood of contamination for all water supplies. Thus, if experts believe that perhaps 60% of point sources are exceeding the target for presence of indicator bacteria but only 20% of piped systems, a “compromise figure” can be calculated based on the proportion of people served by the different technologies. For instance, if 80% of the population rely on point sources and 20% on piped sources, then a weighted estimate would be:  $P = (0.8 \times 0.6) + (0.2 \times 0.2) = 0.5$ .

If the expert opinion approach does not lead to conclusive results, it is best to err towards 50% ( $P = 0.5$ ) in order to maximise the sample size.

### ***Review of existing water quality***

This approach may provide a more reliable estimate of the proportion of supplies that will exceed the water quality target. The process is simple, as it is a case of dividing the number of samples from existing data that exceeded the target by the total number of samples taken. This should then be transformed into a proportion, for example: if 450 out of 1,000 samples exceeded the target, the equivalent proportion is  $P = 0.45$ .

When using existing data, there are three key considerations to bear in mind. Firstly, it is important to evaluate the degree to which the available data are representative. If the results have all been taken at particular times of year (which may therefore be concentrated in particular seasons) then these may not be representative of the time of year in which the rapid assessment will be undertaken. For instance, the quality of many supplies (particularly shallow groundwater sources that are not treated) will be more likely to show significant seasonal variation. This must be considered in terms of the survey design, but also accounted for in the subsequent interpretation of the RADWQ results as bias may be introduced by performing rapid assessments at particular times of the year. It is therefore important to interpret the existing data in light of expert judgement, for example: if the existing data come from wet seasons and the rapid assessment will be performed in a dry season, then the proportion of supplies expected to exceed the target may be reduced.

Secondly, it is important to evaluate the degree to which the available data are of adequate quality. If there are no records of quality control or assurance procedures, then the data may be questionable. In particular, results obtained from non-standard techniques (such as using H<sub>2</sub>S strips to assess bacteriological quality) should not be considered as being of adequate quality unless they have been cross-checked with other techniques and proved to provide reliable results.

Thirdly, it is important to consider whether there are any significant or gross imbalances in the amount of data from different water supplies, which may introduce bias into the survey design. For instance, if 90% of all existing water quality data come from utility-run piped supplies that showed very few samples with the presence of indicator bacteria, this may be highly unrepresentative of point source-fed water supplies in rural areas. A judgement will have to be made of the importance of this – for instance if most people rely on utility supplies then this is not so problematic, but if most people rely on point supplies it will provide highly biased estimates.

When relying on existing data, there are two approaches that could therefore be taken to calculate the sample size. Applying the first approach the sample size will be calculated for *all* water supplies by pooling all available microbial data and use this to calculate the proportion of the water supplies

that are likely to exceed the target. This could be based either on the proportion of total number of samples taken that showed the presence of microbial indicators or on the number of supplies that have at some point shown the presence of microbial indicators, regardless of the number of samples. The proportion in both cases may then require adjustment for season or potential bias using expert judgement.

Applying the second approach the sample size will be determined for *each* technology. For this, the supplies are divided into discrete study populations (e.g. piped supplies and point sources) and the number of supplies to be included within the assessment is calculated for each category. This has the advantage of reducing some of the more gross biases in the survey design. However, this approach will increase the overall sample size and it may become difficult to calculate a reasonable sample size for individual supply technologies. Furthermore, there will be many potential biases that may be introduced and will make the overall survey design more complicated. Further complication may be introduced as the target level of water quality may be different between water supply technologies.

Unless there is a substantial data set covering different technologies and management arrangements, it is recommended that microbial data from all water supply technologies are assessed together without differentiation between the different types. As noted above, however, this may need to be tempered with some expert judgement regarding the overall probable proportion of supplies that are likely to exceed the target.

### ***3.2.2 Design effect***

The design effect (D) is commonly used in cluster sampling techniques to ensure randomness. The design effect is the ratio of the standard error using the actual sample design compared to the standard error of a simple random sample. The greater the homogeneity within a cluster (in other words: potentially reduced randomness), the greater the design effect used. Larger values for D will result in a larger sample size.

When undertaking water quality assessment, the rate of homogeneity within a cluster needs to be carefully considered. Unlike cluster surveys that estimate use of water sources (e.g. MICS) where higher values of D are applied because of the likelihood of neighbouring household using the same water, the likelihood of adjacent water supplies exceeding a target is lower. Studies of microbial quality of water have demonstrated that failures are often localised, because of poor sanitary compliance of a point source or damage to a supply pipe. Thus, adjacent water supplies, including neighbouring piped water zones, can show very different quality (for example, see Howard (2002a)). Similar findings emerge from studies of arsenic in groundwater supplies in Bangladesh, for instance, where adjacent boreholes (often very close together) show very different levels of arsenic, because of uneven distribution of arsenic in groundwater and differences in depth. Furthermore, for many water supplies, the distance between adjacent sources is much greater than between adjacent households. The obvious exception to this is within piped systems, but this can be dealt with by ensuring that within-cluster sampling is spread throughout the entire supply.

In determining the value of D, therefore, existing data and expert judgement need to be applied to estimate what is the likely similarity in water quality in adjacent water supplies. In the pilots implemented as part of the development of the RADWQ approach, a design effect of  $D = 4$  was used for the survey design reflecting the reported variation in water quality from existing data sets and literature. However, in some circumstances a higher or lower value for D may be considered more reliable, particularly when studying a specific parameter.

### 3.2.3 *Bias and precision*

A key aspect of survey design is to ensure that a representative sample is taken from the population under study. When estimating a proportion, therefore, it is important that the estimator is unbiased. Bias means that the estimator selected is skewed to one side or another of the distribution of the data (either higher or lower than the central tendency).

The precision of the estimator is a measure of its accuracy and is usually assessed by considering the variance of the estimator based on the normal distribution. The smaller the variance, the more precise or accurate is the estimator. Variance is a measure of the difference of the actual mean value from the range of possible values.

In devising survey designs there is a trade-off between bias and precision. In general terms, controlling bias (or preventing biased surveys) is considered more important than precision and therefore bias is rarely compromised for precision. There is little value in being precisely wrong, but much value in being imprecisely correct!

In the pilot assessments undertaken, an acceptable precision of  $e = \pm 0.05$  with a confidence level of 95% was used. Other values may be used to increase or decrease the acceptable precision depending on the degree to which managing precision and risk of Type I errors are important.

### 3.2.4 *Summary of sample size calculation*

Using Equation 3.2, the number of “improved” water to be included within the rapid assessment is 1,600 if the proportion is assumed to be  $P = 0.5$ , with a precision of  $e = 0.05$  and a design effect of  $D = 4$ . This is the default number of supplies to be used when information available does not support determination of the expected proportion ( $P$ ) of supplies exceeding a stated water quality target.

**Equation 3.2:** 
$$n = \frac{4 * 0.5(1 - 0.5) * 4}{0.05^2} = 1600$$

Once the required number of supplies to be included within the assessment has been calculated, it is important to review whether it will be feasible to visit this number of “improved” sources of drinking-water and undertake water quality analysis and sanitary inspection. If it is considered that the number of supplies to be visited is too high, then the number of supplies to be included will need to be revised. The revision and justification will need to be documented in the project report.

When looking at equation 3.1, it is obvious that changing the number of supplies ( $n$ ) may be achieved by either changing the proportion ( $P$ ) or the precision ( $e$ ). For instance, if the proportion of supplies estimated to show contamination is fixed at 0.5, the number of supplies included within the study for a precision of  $\pm 0.05$  is 1,600, but for a precision  $\pm 0.1$  it is 400. By contrast, large changes are needed in  $P$  to bring about significant changes in the number of supplies to be included. For instance, using a precision of  $\pm 0.05$ , if  $P$  is set at 0.5 then 1,600 supplies must be included whereas if  $P$  is set at 0.7 the number of supplies required is 1,344.

## 3.3 *Stratifying the sample size*

The following steps are designed to clearly stratify the country in the survey design. The purpose of stratification is to ensure that the survey of water supplies reflects their importance and to ensure geographical spread. This allows the number of water supplies of each technology type and each region to be weighted proportionally to their overall importance.

### 3.3.1 Step 2: Primary stratification

The water supplies are the primary sampling unit for the study. This step calculates the total number of water supplies to be included within the assessment from each technology category. The number of supplies from each category should be based on the proportion of the population that is served by each technology type category. As already discussed in Section 3.1, technologies that either serve less than 5% of the total population or that are classified as “unimproved” will not be considered in the survey design (unless a country explicitly wishes to include significant minor supplies or “unimproved” sources in the assessment). Box 3.1 illustrates the step of primary stratification by using a worked example.

Detailed data at the national level are needed to allow the primary stratification to be made. They particularly must include information on water supply coverage, i.e. proportions of population that are served by each technology category. There may be several sources for such data, including those used to complete the JMP reporting form (discontinued after 2000), recent DHS or water sector statistics. Information available may be spread over several institutions at different levels (e.g. regional or national bodies), and frequently efforts need to be made to obtain all information required for the purpose of the survey design.

#### Box 3.1: Worked example – Primary stratification

The *Republic Osmiga* decided to carry out a countrywide assessment of drinking-water quality by using the RADWQ methodology in order to obtain a statistically representative snapshot of drinking-water quality for “improved” drinking-water sources. A national team of experts from various institutions was established to design, plan and implement the assessment.

As a first step, the national team compiled water quality and supply coverage data from various national and regional bodies. The review of water quality data of the previous five years led to the conclusion that the overall sample size of the assessment amounts to 1,600 as the proportion of supplies that exceed the water quality target set for microbial quality (i.e. 0 TTC per 100 ml) was estimated at 0.5 (see Section 3.2).

The primary stratification of the sample size was carried out on the basis of national coverage data on populations served by each technology category. A particular difficulty in interpreting the data was to distinguish between those point sources (i.e. boreholes and protected springs) that feed a piped water system and those that are actually used as a point source, i.e. where people go and collect water (see Section 3.1). Informed expert judgement from within the team and from regional authorities was used to adapt the original coverage data set for the purposes of the RADWQ.

The data showed that 75% of the total population (44.0+16.5+2.5+9.5+2.5) had access to “improved” sources but that two types of “improved” sources each served <5% of the total population so that primary stratification was applied to 70% of the total population (44.0+16.5+9.5). The result of this primary stratification was that 1,006 utility-piped supplies, 377 boreholes and tubewells (used as point sources) and 217 protected springs were included in the rapid assessment study.

Technology category	Population served	Inclusion in survey?	No. of supplies included
Utility-piped supplies	44.0%	Yes <sup>1</sup>	1,006 = 1,600×(44.0/70)
Boreholes and tubewells	16.5%	Yes <sup>1</sup>	377 = 1,600×(16.5/70)
Protected dug wells	2.5%	No <sup>2</sup>	0
Protected springs	9.5%	Yes <sup>1</sup>	217 = 1,600×(9.5/70)
Tanker services	2.5%	No <sup>2</sup>	0
Community rainwater systems	0.0%	No <sup>2</sup>	0
Open sources (ponds, canals)	25.0%	No <sup>3</sup>	0
Total	100.0%		1,600

1: “Improved” technology that serves more than 5% of the total population.

2: “Improved” technology that serves less than 5% of the total population.

3: “Unimproved” technology.

### **3.3.2 Step 3: Secondary stratification**

This step will further sub-divide the sample size for each technology category between broad areas on the basis of administrative boundaries or other characteristics in order to ensure that there is a reasonable geographical spread of water supplies included within the assessment.

This is achieved by considering whether there are any very broad level categories that define key differences within the country. These could be geographical, hydrological, administrative or socio-cultural. These should be based on current national approaches or understanding and not categories created solely for this assessment.

An example of this broad differentiation comes from Nepal where, although there are 75 Districts, there is an accepted division of the country into three key geographical regions: mountains, foothills and Terai. The rapid assessment procedure would want to take these differences into account as they may affect the quality of supply. They also make a useful stratification, as it reduces the risk of bias in the selection process from regions with lower populations (for instance in mountain regions).

Data required for this stratification step are the number of existing supplies for each technology category aggregated per broad area. At this stage it is important to bear in mind that large piped water supplies are sub-divided into zones and that each zone is defined as a separate “improved” drinking-water source (as described in Section 3.1.2).

Usually such aggregated data will be readily available for large administrative units within a country (e.g. provinces, states or regions) rather than for other broad area classifications such as geographically or hydrologically defined areas. However, existing data sets for administrative levels may well be used to estimate the distribution of data for any other broad area classification.

In situations where technology-specific data on the number of existing water supplies are not readily available, ways need to be found to estimate the number of supplies for each technology category and broad area. One option for doing this is to start with data on total populations served by individual technology categories in broad areas, if available. Then average values for population sizes served by individual technology types can be used to estimate the number of water supplies per broad area. Such average values may be derived from informed expert judgement, using topographic and hydrogeological information, and broad area specific data on populations in rural or urban settlements, for example.

Box 3.2 on the next page continues the worked example of Box 3.1 illustrating the step of secondary stratification. The example also highlights the degree of flexibility that is needed when applying the RADWQ methodology.

### Box 3.2: Worked example – Secondary stratification

The *Republic Osmiga* is divided into seven States, each of them subdivided into several Districts. The States were grouped into three broad areas (i.e. BA A, BA B and BA C; see figure right-hand) as this division was the most accepted broad division within the country in terms of geographical categories (e.g. mountainous, plateau and flatland areas).

Data on the existing number of water supply technologies were collected from relevant State authorities and aggregated per broad area (as shown in the first table below). For utility-piped supplies, the number of (theoretical) supplies or zones was calculated by dividing the total population served by this technology by 5,000, as suggested in Section 3.1.2, rather than using the number of utilities (in terms of management units).

It turned out, however, that the number of (theoretical) supplies (i.e. 1,300, as shown in the first table below) determined for the whole *Republic Osmiga* was only slightly higher than the total number of piped supplies to be included in the study according to the results of primary stratification (i.e. 1,006, as shown in Box 3.1 and in the second table below).

In practice the assessment for piped supplies would have included approximately 77% ( $= (1006 \div 1300) \times 100\%$ ) of the piped supplies. This situation was seen as not desirable, particularly because this would have significantly increased the cost and time for the assessment. Therefore, due to practicality issues, time limitations and costs the national team decided to modify the survey design and to reduce the zone size from 5,000 to 2,500. This would calculate a higher number of (theoretical) supplies (i.e. 2,600; see table below) and would mean that only ca. 39% of the piped supplies were visited in the study.

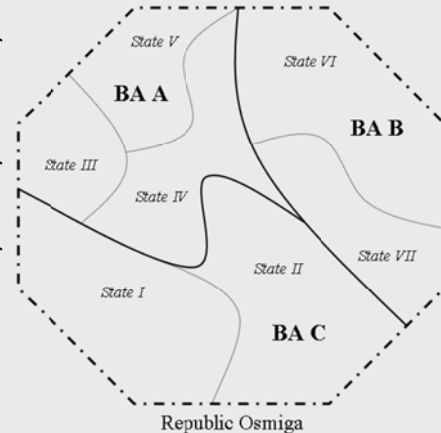

Technology category	Broad area A	Broad area B	Broad area C	Total Republic
Utility-piped supplies:				
– Population served	2,600,000	3,250,000	650,000	6,500,000
– 5,000 zone size	520 (=40%)	650 (=50%)	130 (=10%)	1,300 (=100%)
– 2,500 zone size	1,040 (=40%)	1,300 (=50%)	260 (=10%)	2,600 (=100%)
Boreholes and tubewells	500 (=20%)	1,250 (=50%)	750 (=30%)	2,500 (=100%)
Protected springs	180 (=10%)	720 (=40%)	900 (=50%)	1,800 (=100%)

As there are three broad areas in the *Republic Osmiga*, the areas are included with the three water supply technology categories selected in primary stratification to give a total of nine groups (i.e.  $3 \times 3$ ). The number of water supplies of each technology type category from each area included in the study is proportional to the number of supplies of that type within a particular area (as per table above). The table below shows the results of the secondary stratification for the *Republic Osmiga*, i.e. the number of supplies per technology and technology category to be included in RADWQ.

Technology category	Broad area A	Broad area B	Broad area C	Total Republic
Utility-piped supplies	402 (=40%)	503 (=50%)	101 (=10%)	1,006 (=100%)
Boreholes and tubewells	75 (=20%)	189 (=50%)	113 (=30%)	377 (=100%)
Protected springs	22 (=10%)	87 (=40%)	108 (=50%)	217 (=100%)

#### 3.4 Step 4: Defining cluster size

Before the actual water supplies to be included within the survey are determined, it is important to define how many clusters will be required. As a means of overcoming some of the inherent problems with homogeneity within cluster sampling, it is important to establish a minimum number of clusters that will be visited. Within RADWQ studies, the minimum number of clusters recommended is five per technology to ensure a reasonable geographical spread and allowance for other influencing factors.

The number of clusters is determined on the basis of practical considerations, taking into account the need to both ensure a representative spread of clusters across the country and address logistical issues regarding travel between clusters. The clusters themselves should be defined so as to minimise the amount of travel within the cluster. For example, for piped water supplies, clusters



may be defined based on the number of areas within a water system that can be feasibly visited within one day. For small, community-managed piped water systems this may mean a cluster includes more than one system, whilst for utility-managed systems a cluster more likely refers to a single system. For point sources, clusters should also be defined on the ease of movement, for instance a village with several water supplies may represent a single cluster. Criteria established for cluster size must guarantee that the minimum number can be selected and documented.

As a practical approach, one option may be to consider defining cluster size on the basis of the number of water supplies that can be visited by one field team within one week made up of four working days in the field, leaving the fifth day for planning the field work, reading results, quality control procedures, calibration of instruments, preparation of media and submission of results. It is difficult to define a number of supplies that can be visited within a week that has broad applicability. Table 3.2 provides some suggested minimum and maximum figures, but it should be emphasised that the number selected should reflect local conditions and so may vary between broad areas. Box 3.3 continues the worked example illustrating the step of defining cluster sizes and calculating the number of clusters required.

**Table 3.2: Suggested range of water supplies that can be visited by one field team in one week**

Technology type	Minimum cluster size	Maximum cluster size
Point sources (i.e. boreholes, tubewells, protected springs, protected dug wells)	12	40
Utility-piped supply zones	20	50
Community-managed piped supply	4	12
Tanker supplies	12	50

**Box 3.3: Worked example – Cluster size definition and cluster calculation**

Cluster sizes were selected individually for each technology and broad area so as to adequately reflect local conditions. The national team reviewed the different factors for each broad area, including accessibility of remote districts, availability of electricity, types of vehicles available for the survey as well as presumed road and weather conditions, and then set the cluster sizes given in the table below. For broad areas A and B cluster sizes for piped supplies (i.e. 40) and point sources (i.e. 15) are the same due to similar topographic conditions (mainly flatland), general good road conditions and proximity between settlements. Cluster sizes in broad area C are comparatively lower (i.e. 30 and 10 for piped supplies and point sources, respectively) due to its mainly mountainous characteristics limiting travel and access to settlements.

Technology category	Broad area A	Broad area B	Broad area C	Total Republic
Utility-piped supplies:				
– No. of supplies	402	503	101	1,006
– Cluster size	40	40	30	
– Clusters required	11	13	4	<b>28</b>
Boreholes and tubewells:				
– No. of supplies	75	189	113	377
– Cluster size	15	15	10	
– Clusters required	5	13	12	<b>30</b>
Protected springs:				
– No. of supplies	22	87	108	217
– Cluster size	15	15	10	
– Clusters required	2	6	11	<b>19</b>

As a consequence of cluster size selection, there are in total 77 (i.e. 28+30+19) clusters to be included in the assessment for the *Republic Osmiga* as a whole. Thus, according to the definition of a cluster, one field team would need to work for 77 weeks in order to carry out the full assessment. The national team, however, decided to employ a total of four field teams for the rapid assessment project and therefore each team needed to visit 19 or 20 clusters, respectively, which limited the overall study time to approximately four months.

### 3.5 Step 5: Defining and selecting sampling units

At this stage areas based on sub-national division are defined from where specific clusters are selected. The most appropriate sub-national divisions for this stratification are the principal administrative divisions within the country. These could be states in federal systems, provinces in large countries or districts in smaller countries. These are areas referred to as “sampling units”.

Sampling units included in the survey are selected using proportional weighted sampling: a stepwise explanation is given below (steps 5A-5E). The tables given in the worked example in Box 3.4 correspond to the steps below and aim at illustrating them.

#### Step 5A

For each combination of technology category and broad area a table with three columns is prepared:

- *1<sup>st</sup> column*: list of sampling units where a particular technology is present. If a sampling unit does not have a particular technology, then it is excluded from the list for that technology. The order of the sampling units in the table should be random (e.g. in alphanumerical order, using assigned identification labels for each sampling unit).
- *2<sup>nd</sup> column*: number of supplies existing in each of the sampling units listed.
- *3<sup>rd</sup> column*: cumulative number of supplies determined from the previous column.

If, for example, there are three technologies selected in primary stratification and five broad areas identified during secondary stratification, then 15 proportional weighting tables would need to be prepared.

#### Step 5B

For sampling units where the number of existing water supplies is less than the selected cluster size (Section 3.4), the proportional weighting table needs to be re-arranged (because the cluster cannot be selected from the sampling unit as it has too few water supplies). The re-arrangement is achieved by combining that sampling unit with a geographically neighbouring sampling unit and adding up the numbers of existing water supplies. This procedure creates a new and bigger sampling unit (out of two) that has a sufficient number of supplies and from where the cluster can be easily selected, without compromising the benefits of geographical proximity.

#### Step 5C

For each proportional weighting table, calculate a sampling interval to be used in selecting the sampling units. The sampling interval is calculated to one decimal place by using Equation 3.3 which is based on UNICEF (2006):

**Equation 3.3:**

$$SI = \frac{Tc}{N}$$

SI	Sampling interval
Tc	Cumulated number for total supplies in broad area
N	Total number of clusters required in broad area

#### Step 5D

A random number is selected that is less than or equal to the sampling interval (i.e. between 1 and the sampling interval number). Selecting a random number can be done, for example, by employing standard spreadsheet computer software or from the web (e.g. <http://www.random.org/>).

### Box 3.4: Worked example – Definition and selection of sampling units

The national team decided to use the administrative unit of “districts” as the principal sampling unit from which the clusters are to be selected. In the *Republic Osmiga* all States are sub-divided in several districts, as shown for broad area B in the right-hand figure (i.e. districts D1-9).

As data on the number of existing supplies per district were available, the selection of sampling units could be done by employing the method of proportional weighting according to the steps suggested in Section 3.5. In what follows below, the individual steps are documented for the example of protected springs in broad area B. Corresponding procedures were followed for the eight other technology/broad area combinations.

**Step 5A:** The left-hand table below lists all districts in broad area B (see also right-hand figure) in alphanumerical order as well as numbers of protected springs per district; the third column shows the cumulative number of supplies.

**Step 5B:** As the number of existing springs in district 3 (i.e. six) falls below the calculated cluster size of 15 (see Box 3.3) the weighting table was re-arranged, as shown in the right-hand table below. As district 3 is an enclave of district 1 (see figure on the right), both were combined to a new sampling unit (i.e. “districts 1 and 3”) by adding up the numbers of existing supplies.

**Step 5C:** The sampling interval was calculated according to equation 3.3. The total number of protected springs in broad area B is 720 (see Box 3.2) and the number of clusters required is six (see Box 3.3). Thus, the sampling interval (SI) calculates to  $SI = 720/6 = 120$ .

**Step 5D:** A random number of 55 was selected using a spreadsheet programme.

**Step 5E:** By using the re-arranged weighting table on the right-hand below and following the selection procedures, the following six districts were selected as sampling units in broad area B:

- The first sampling unit selected is *district 2*, which is the first area whose cumulative number of springs (i.e. 67) exceeds 55 (the random number).
- The second sampling unit selected is *district 5*, which is the first area whose cumulative number of springs (i.e. 212) exceeds 175 (i.e. the total of the random number (=55) plus the sampling interval (=120)).
- The third sampling unit selected is *district 6*, which is the first area whose cumulative number of springs (i.e. 496) exceeds 295 (i.e. the total of the previous interval (=175) plus the sampling interval (=120)).
- The fourth sampling unit selected is again *district 6*, which is the first area whose cumulative number of springs (i.e. 496) exceeds 415 (i.e. the total of the previous interval (=295) plus the sampling interval (=120)).
- The fifth sampling unit selected is *district 7*: first to exceed 535 (415+120).
- The sixth sampling unit selected is *district 9*: first to exceed 655 (535+120).

In summary, there are in total five districts from where the six clusters will be selected: one cluster from each of districts 2, 5, 7 and 9; and two clusters from district 6.

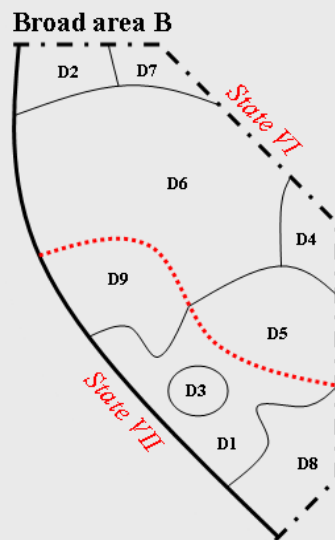

Proportional weighting table: Protected springs in broad area B			Re-arranged proportional weighting table: Protected springs in broad area B		
Sampling unit	No. of protected springs in unit	Cumulative number	Sampling unit	No. of protected springs in unit	Cumulative number
District 1	38	38	Districts 1 and 3	38+6	44
District 2	23	61	<b>District 2</b>	23	<b>67</b>
<b>District 3</b>	<b>6</b>	67	District 4	65	132
District 4	65	132	<b>District 5</b>	80	<b>212</b>
District 5	80	212	<b>District 6</b>	284	<b>496</b>
District 6	284	496	<b>District 7</b>	55	<b>551</b>
District 7	55	551	District 8	78	629
District 8	78	629	<b>District 9</b>	91	<b>720</b>
District 9	91	720			

### ***Step 5E***

From the weighting table, select the sampling unit whose cumulative number equals or just exceeds the random number.

If more than one large area sampling unit is required, select the next sampling unit by adding the sampling interval to the random number and select the unit that equals or just exceeds this number. In most cases several sampling units need to be selected and to do this add the sampling interval to the previous number calculated and select the area whose cumulative number of supplies exceeds the new number. This is repeated until the required number of sampling units has been selected.

In situations where statistical data on the number of supply schemes per technology and sampling units are absent, proportional weighting cannot be used to select the sampling units from within the broad areas. Thus, alternative selection methods need to be sought, depending on the availability of information that allows a sensible selection of sampling units.

The use of expert judgement is one example of such an alternative method. Applying expert judgement, sampling units are selected by considering factors such as the geological, hydrological and geographical conditions of a region, the spatial distribution of sampling units, and assumptions about whether there are enough individual supply technologies in a sampling unit to build a cluster.

In order to maintain the essential “random element” in the survey design, proportional weighting can be carried out at the secondary step. Using an alternative method to the worked example presented in the boxes, firstly the States to be included in the RADWQ study could be selected by proportional weighting (i.e. according to steps 5A-5E above), and secondly sampling units from within selected States can be chosen based on expert judgement.

### ***3.6 Step 6: Selecting clusters and water supplies***

The final step is to define the clusters and to identify the exact supplies to be visited in the sampling units identified in Step 5. This is done by listing all the supplies for each technology type and allocating them to clusters. The cluster should be defined as a number of water supplies that are sufficiently close to one another to ensure that they can all be visited within one week as discussed in Step 4. Remote water supplies that are not sufficiently close to other supplies and are too few to form a separate cluster may be excluded from the analysis if their inclusion would raise unacceptable logistic difficulties. Each cluster should then be assigned a number. At the end of this stage, a table that details all the clusters identified and their geographic location should be compiled and used to allocate specific areas (clusters) to specific survey teams.

For each combination of sampling unit and supply technology identified in survey design Step 5, individual sources need to be selected for building the clusters, as shown by the two examples given in Box 3.5. Where detailed information on the number and location of individual sources within a sampling unit is not available, on-site decisions need to be made by the field teams on the basis of consultations with staff from local or regional institutions and/or the local population. These decisions need to be documented in the project report.

A more detailed description of practical considerations in sample point selection, particularly for large piped supplies, is presented in Chapter 4.

### Box 3.5: Worked example – Selection of cluster and water supplies

As illustrated in Box 3.4, district 2 was selected as one of the sampling units from which a cluster of protected springs is to be formed. The cluster size was determined as 15 (see Box 3.3) which means that 15 springs need to be selected out of the total of 23 (i.e. springs A-W) which are located in the district (see figure below left). In order to ensure easy and effective travel between individual sources within the cluster, the national team decided to select those springs which are located reasonably close to the main road. Thus, the supplies marked by a circle in the left-hand figure below were selected to build the cluster in district 2.

The figure below right illustrates the selection of utility-piped supplies from district 2. In total, five utilities are located in district 2 (i.e. utilities A-E). Using the 2,500 person criterion for sizing supply zones (see Box 3.2), 53 supply zones (or theoretical supplies) can be calculated. The cluster size for piped supplies was determined as 40 (see Box 3.3) which means that 40 supply zones need to be selected out of the total of 53 which are located in district 2. The national team decided to select utilities A and B only for building the cluster. Both utilities contain a total of exactly 40 supply zones.

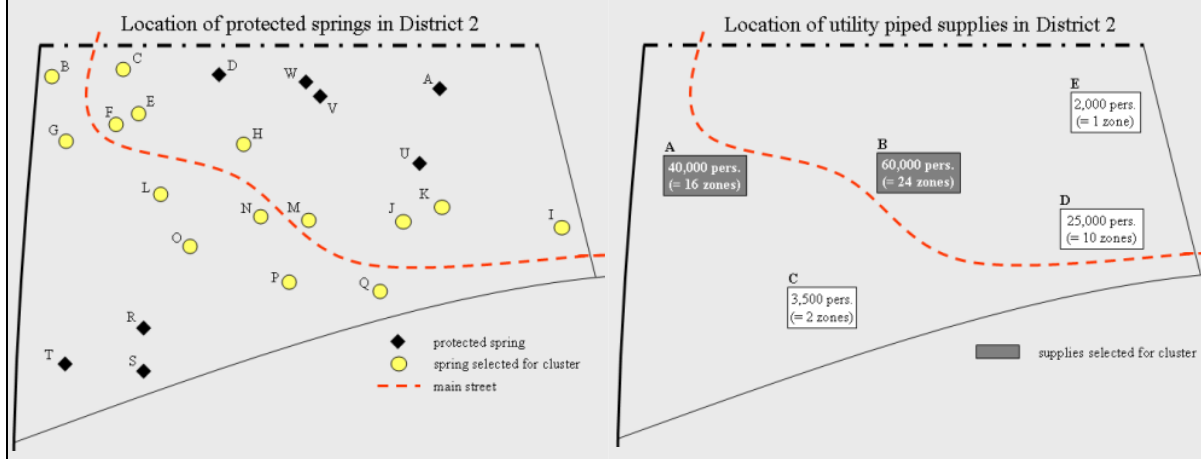

### 3.7 Summary of data requirements

A prerequisite for applying the method outlined in Sections 3.2-3.6 is the availability of a range of data and information, summarised as the “optimum” data set in Table 3.3. The worked example given in Boxes 3.1-3.5 illustrates the use of the RADWQ method assuming that the optimum data set is available.

However, in reality the optimum data will not always be available, and therefore Table 3.3 also indicates a “minimum” data set which is required to successfully apply the RADWQ method. In various sections above brief indications are given on how to employ the minimum data in order to design the survey. As the use of the minimum data set involves a range of informed expert judgements, efforts should be made to increase data availability (e.g. by adapting national drinking-water supply related information collection and reporting schemes) in order to strengthen the basis for future assessments,

In situations where the minimum data set is not available, the RADWQ method cannot be reliably applied. In this case the first step is to collect adequate data and information. This exercise has a significant value in itself as it helps developing an understanding of the drinking-water supply situation in a country or region and targeting efforts for any regular future data collection and reporting schemes.

**Table 3.3: RADWQ data requirements**

Survey design process		Data required	Optimum data set	Minimum data set
Step 1	Calculation of sample size	Water quality	Data for all microbial indicators and chemical parameters of health significance Data divided by different water supply technologies (i.e. piped supplies vs. point sources) Data for at least the previous five years	Informed expert judgement on the water quality situation in the country Review of individual studies or reports
Step 2	Primary stratification	Population coverage	Current statistical data on proportions of populations served by individual water supply technology categories (i.e. “improved” and “unimproved” technologies) Data to be collected for the first administrative (i.e. national) level	Informed estimates on proportions of populations served by individual water supply technology categories (i.e. “improved” and “unimproved” technologies) Data to be collected for the first administrative (i.e. national) level
Step 3	Secondary stratification	Water supply coverage	Data on numbers of existing water supplies by individual water supply technology category Data to be collected for the <u>second</u> administrative level (e.g. provinces, states or regions) or broad areas	Data or informed estimates on average numbers of populations served by individual water supply technologies Current statistical data or informed estimates on populations served by individual water supply technology categories Data to be collected for the second administrative level (e.g. provinces, States or regions) or broad areas
Step 4	Definition of cluster sizes	Maps and other information	Administrative, topographical and road maps as well as information or predictions on weather and road conditions	Administrative, topographical and road maps as well as information or predictions on weather and road conditions
Step 5	Definition and selection of sampling units	Water supply coverage	Data on numbers of existing water supplies by individual water supply technology categories Data to be collected for the <u>third</u> administrative level (e.g. districts or municipalities)	Data as defined in step 3 Informed estimates on the presence of individual water supply technology categories in sampling units (i.e. districts or municipalities)
Step 6	Selection of clusters and water supplies	Water supply inventory	Information on the exact location of individual sources within sampling units (i.e. districts or municipalities) Administrative, topographical and road maps	On-site information on location of individual sources within sampling units (i.e. districts or municipalities) Administrative, topographical and road maps

### 3.8 Summary of survey design steps

To undertake the survey design, it is necessary to complete the following tasks:

- Establish that only water supplies serving a minimum number of people will be included in the population to be surveyed. Unless you have good evidence to suggest otherwise, use 200 for point sources.
- Collect data on water quality, populations served by different supply technologies, numbers of supplies per technology as well as the location of water supplies within the country (as summarised in Section 3.7).

- For piped supplies, undertake zoning.
- Decide which supply technologies are to be included in the survey, based on the purpose of the survey and on the population covered.
- Set the proportion (P) and precision (e) for the survey. Unless you have good evidence to suggest otherwise, use a P value of 0.5.
- Calculate the sample size required using equation 3.1. Unless you have good evidence to suggest otherwise, use 1,600.
- On the basis of the proportion of the national population using each technology type, allocate the appropriate proportion of samples to each technology (primary stratification).
- Undertake secondary stratification of the country into broad areas.
- Define the cluster size and calculate the number of clusters required for each technology and broad area.
- Define the sampling units (e.g. district, province or State).
- For each technology and each broad area prepare a list of sampling units that contain the technology. Using the number of clusters required calculate the sampling interval and select a random number. Select the sampling units as described in Section 3.5.
- Select clusters and individual sources to be visited from within the sampling units.

### ***3.9 Review of sampling issues for this handbook***

This version of the handbook proposes to visit in each country a sample of around 1,600 Water Supply Points, selected in two stages, with districts (small area units) in the first stage and individual Water Supply Points in the second stage. The first sampling stage is stratified by technology and by regions (broad area units), allocating the total sample size proportionally to the distribution of the population according to these two criteria. In the second sampling stage, Water Supply Points are selected for convenience, striving to minimize the fieldworkers' transportation efforts.

This version of the handbook also proposes to visit around 800 households, five in each of 160 Water Supply Points, selected with equal probability from the total sample of 1,600 Water Supply Points.

A meeting of sampling experts in June 2012 in Geneva suggested an alternative design that would address sampling problems identified, by way of defining the sample of Water Supply Points on the basis of the standard methods and procedures of household survey sampling. This approach would also create the basis for rapid assessment of drinking-water quality without linking this to the MDG-defined concepts of improved sources of drinking-water. In other words, it would allow for a complete drinking-water quality assessment irrespective of source.

In brief, the observed Water Supply Points would be a random sub-sample of those actually used by a sample of the population (as reported by a household survey), or by the whole population (as reported by the census). The details of this alternative approach will be specified in a next, revised version of this handbook.



## 4 FIELD IMPLEMENTATION

Once the survey design is completed and the clusters of “improved” drinking-water sources identified, using the methodology described in Chapter 3, then the work plan for the field activities for the survey needs to be developed. The plan should enable the field teams to provide the data required by the survey design but also needs to be sufficiently practical as well as efficient in terms of costs and time. The procedures and steps for development and practical implementation of a work plan for RADWQ surveys are outlined below. These are based on implementation taking place over a continuous period.

### *4.1 Establishment of teams for survey management and implementation*

#### *4.1.1 Inter-sectoral RADWQ management team*

As mentioned in Chapter 2, successful implementation of RADWQ programmes requires the establishment of an inter-sectoral RADWQ management team with clearly specified terms of reference. The team should be coordinated by a senior staff member from the Ministry of Health, Ministry of Water or Ministry of Environment. The choice will depend on the objectives of the assessment and on the country-specific designation of responsibilities for water quality monitoring and surveillance. If there is a national regulatory body for drinking-water quality then this should have a lead role in supporting and facilitating the RADWQ process.

The core tasks of the management team include the following:

- overall programme management and co-ordination, including collaboration with relevant stakeholders (specifically those not represented on the management team) and existing water quality and surveillance programmes;
- budget planning and oversight;
- survey design, including identification and collection of existing data required for the design;
- selection of parameters and sampling frequency of individual parameters;
- selection of equipment;
- field work planning (including team selection, training, purchase of equipment and consumables, transport and logistics) and oversight of its implementation;
- management and analysis of data;
- production and dissemination of progress and final reports on the assessment, including recommendations for future actions; and
- trouble shooting in case of unforeseen challenges in the assessment process.

The composition of the inter-sectoral management team will vary from country to country and will largely depend on national institutional structures and responsibilities for water quality monitoring and surveillance. It is recommended that the management team does not become too large, and a maximum number of ten people is recommended to prevent it becoming too unwieldy and hindering decision-making. At a minimum, the team needs to include personnel with expertise in drinking-water quality microbiology and chemistry; field implementation of water-related programmes; and statistics relevant to both survey design and data analysis and management. It is recommended that the day-to-day management of specific tasks of the management team is assigned to individual team members (e.g. a field coordinator for planning, supporting and overseeing field work) as this will increase the efficacy of RADWQ programme implementation. At least one statistician is required to oversee the survey design and data analysis. This person should have experience in survey design and also be confident in undertaking a range of statistical analyses of non-parametric data. Also, one person should be responsible for management of data entry into

the database and for providing raw, summarised and analysed data. This could be the statistician or could be an additional team member. Data management and analysis are discussed in more detail in Chapter 8 and Annex 6.

A core responsibility of the management team is to agree which institutions, organisations and/or individuals will undertake the field activities. There is no particular recommended approach, although the use of government institutions may provide a lower cost approach as only travel and subsistence would usually be required. If government staff are used, it is recommended not to make additional payments for staff time, as this may ultimately lead to problems in establishing longer-term monitoring and surveillance programmes. The institution(s) selected for the field-work should have the appropriate staff, in terms of both skills and numbers, to be able to undertake the field activities without compromising day-to-day routine institutional responsibilities. As some laboratory checking of field results may be performed, it is important that the institution used has its own laboratory or has access to such facilities.

In some situations, the management team may not have the capacity to carry out all tasks (e.g. the team may not be in the position to undertake the full survey design and/or data analysis). Consequently, it will be necessary to identify appropriate institution(s) or external experts to assist in these activities. This may be same institution that performs the field studies, if they can demonstrate that they have the full range of required skills or can bring these in from another institution. It may be necessary to use a separate institution to undertake the survey design and/or data analysis in collaboration with the institution(s) undertaking the field study and if so, then the management team must identify how they expect the different organisations to interact.

The management team or the field coordinator, respectively, will need to support the field teams in their day-to-day management (e.g. provision of advice if any of the equipment fails, identification of alternative sampling sites or if other back-up is required). In addition, the field coordinator should make at least one supervisory visit to each of the field teams during the survey to check on their progress and compliance with field techniques (e.g. aseptic technique).

#### **4.1.2 Field teams**

A number of field teams, responsible for all the water quality analysis and sanitary inspections, will need to be selected and trained for the purposes of RADWQ. Each team should have a minimum of two people to be able to reduce the time at each sampling point, as one person can be testing for physical and chemical parameters whilst the other is doing the microbial testing (a suggested order for testing is given in Section 4.3.5). The number of field teams required will be determined by the timeframe available for the survey and logistical factors, such as the amount of equipment available. For example, to complete analysis at 1,600 sites within four to six months it is recommended that at least four field teams (each of at least two people) are appointed, with an additional or reserve team being available to relieve members in the field, if necessary.

Team members should be trained water quality professionals, preferably with practical experience in water quality sampling procedures and analysis as well as of using field equipment, who are fit and able to undertake rigorous field-work for extended periods of time. Ideally all field team members should be able to carry out all types of water quality analysis and also sanitary inspections. The field staff team should include chemists and, preferably, microbiologists. If there are no microbiologists available, then other water quality analysts may be used, provided they have previously undertaken some microbial analysis of water. If staffing and budget allow, each team may include a sanitary or environmental health engineer as an additional (i.e. third) team member, with particular responsibility for carrying-out sanitary inspections. In situations where this is not possible, it is a prerequisite that all field team members are thoroughly trained by environmental

health experts on the background and practical undertaking of sanitary inspections (including practical training exercises in the field). No members of the field team should be included who do not have current training and experience of water quality testing, and if these are proposed to the management team they should be rejected.

## **4.2 Work plan development**

### **4.2.1 Requirements**

The main aims of the management team when drawing up the work plan for implementation of a RADWQ programme are to:

- agree on and finalise the output from the survey design (i.e. technologies, clusters, geographical spread etc.);
- finalise the range of indicators/parameters and procedures to be included in the survey. The core set of indicators/parameters recommended for basic/initial assessments is discussed in Chapters 5 and 7;
- decide on the frequency of indicator/parameter testing (i.e. whether to test for every indicator/parameter for every water sample). In general, provided that there are adequate resources, all indicators/parameters should be determined at every site unless there is good evidence to exclude particular ones (e.g. only include chlorine residuals for chlorinated supplies and only measure copper in households with piped supplies). There may be survey-specific indicators/parameters that are to be tested only in specific areas or only for particular technologies (see Chapters 5 and 7);
- decide on the methods of analysis. As discussed in Chapters 5 and 7, field-based methods are recommended for basic/initial assessments; where field equipment is used, it should employ accepted standard methods;
- agree on and finalise the formulation and format of the sanitary inspection forms to be used. The formulation of sanitary inspection forms is discussed in Chapter 6 and Section 4.3.3, with recommended forms for each technology type being provided in Annex 2;
- agree on a coding system which clearly assigns unique numbers to individual sampling points;
- coordinate data collection, analysis and reporting procedures (see Chapter 8);
- organise when and where the field teams will collect data, i.e. which teams will visit which clusters and when they will do so (see Section 4.2.2 below);
- ensure that field, data management and analysis personnel are in place and have received adequate training in the methods and procedures required. In some countries analytical experience is principally laboratory-based so training in the use of field equipment and sanitary inspection techniques will be paramount;
- ensure that all equipment and consumables for analysis have been purchased and are functioning and available to the teams as and when required. Wherever possible, equipment and consumables should be purchased locally; for some consumables, such as methanol, this is essential (as air transport is problematic). When it is necessary to import equipment and consumables, adequate time will need to be built into the work plan to ensure that all requirements are in place in advance of the start of the field work. If consumables are imported, it is essential to ensure their shelf life goes beyond the duration of the survey;
- ensure that operational vehicles and drivers are available and that provisions for fuelling and servicing of vehicles are in place;
- ensure that all equipment and programmes for data storage and analysis have been purchased and are available as and when required. Data requirements need to be established well in advance of the field work otherwise it is possible that inadequate data will be collected, thus negating some or all of the survey;

- ensure that communication strategies between field teams and the management team are established (e.g. agreed frequency and mechanisms for submitting results to the field work coordinator and/or the data manager) and that technical provisions are in place that ease the communication (e.g. through distribution of mobile phones);
- agree on how and to whom the results of the RADWQ are to be reported and disseminated. Ideally, this should be established prior to commencing the field work; and
- ensure that the budget is adequate to cover all aspects related to the RADWQ programme, including purchase of equipment and consumables, training arrangements, transport and subsistence arrangements for field teams, drivers, the field coordinator, and also for management team meetings and reporting and dissemination of survey findings.

Many of the items on the above checklist are common to all surveys but it is especially important for a rapid survey to check that all components are in place before field work starts. One common constraint when the methodology was piloted was adequacy of funding for transport and staff subsistence payments, items which are often the largest components of the overall budget and, if not adequately funded, can cause problems during implementation. It is essential, therefore, when drawing up the work plan and setting budgets for rapid (or any) assessments to address these issues thoroughly.

#### ***4.2.2 Drawing up the work plan***

The management team or the field work coordinator is responsible for developing a comprehensive work plan that encompasses all information required for guiding field implementation. It is advisable that the field work coordinator develops the work plan together with the field team members to ensure that the work plan meets their needs and is well understood.

The following considerations are important to remember (see also Chapter 3) when developing the work plan:

- Each cluster identified during the survey design is equivalent to one week's work for a field team. Thus, the total number of clusters across all technology categories is equivalent to the total number of project field team weeks.
- The given time frame for field work implementation will determine the number of field teams to be established. For example, if a total 80 clusters were identified in survey design and the overall project time available for field implementation is five months or 20 weeks, respectively, then a minimum of four field teams need to be established.
- When developing the work plan each field team should be given responsibility for particular sampling units (e.g. districts) within the country from which the clusters are to be selected. Thus, the work plan should provide week-by-week information about which field team visits which sampling unit in which week.
- The work plan should also specify the number of household samples and specific clusters from which samples need to be taken by individual field teams (see also Section 4.3.2).
- Assigning particular sampling units (e.g. districts) to individual field teams and planning the sequence of sampling units to be visited by individual teams will be primarily guided by ease and effectiveness of travel and logistical considerations, such as geographical proximity of sampling units, the accessibility of remote areas (e.g. weather conditions, including the impact of rain or cold, road conditions, availability of 4-wheel-drive cars), travel times or availability of accommodation (see also Box 4.5). Work plan development therefore requires availability of administrative, topographical and road maps for locating transport routes and accommodation options in addition to sampling points.
- The level of detail provided in the work plan will depend on the availability of information at the outset. While the survey design will identify the sampling units (e.g. districts) to be

visited for cluster selection, the exact location of the water supplies that form a cluster and need to be sampled will not be available in all situations. If information on the exact location of individual sources within sampling units is available, the actual work plan will provide detailed information on the names of towns and villages or even names of individual sources to be visited for sampling. If such a detailed inventory is not available, the work plan will, instead, provide information on the names of sampling units only. It is then the responsibility of the field teams to collect on-site information (e.g. from the local authorities or the local population) on the location of individual sources within sampling units. This will be more time-consuming and needs to be accounted for in the work plan.

- It is advisable that an initial two-week period is scheduled in the work plan where all field-teams are based in one broad area. Teams will be able to meet during this period to learn from each other's experiences. This will aid consistency in analysis and inspections, and help to resolve any issues with procedures prior to teams separating to complete their allocated clusters. If required, revisions to team membership, checklists for field work etc. can also be made during this period.
- It is advisable to plan for at least one working break during the field implementation period for a mid-term meeting of all the teams in order to jointly monitor progress and make any revisions to the original work plan. In addition, a leisure break is advised because the field work is intensive with long days in the field collecting and analysing samples, plus additional time being spent preparing for the following day's programme, reading microbial counts before setting out each day and ensuring records are up-to-date and despatched to the coordinator on-time. In addition, national holidays need to be taken into account.
- The full work plan would also contain provision for announced and unannounced visits by the coordinator.
- Where possible, the work plan could name sites where the teams will be accommodated.

For the purpose of illustrating some of the issues important for developing of a work plan for field implementation of basic/initial rapid assessment, Boxes 4.1 and 4.2 continue the worked example for the *Republic Osmiga*, as introduced in Chapter 3.

Under certain circumstances, it is possible that the work plan will require further modification during planning and even during implementation of the survey. For example, unforeseen budgetary constraints may influence the availability of equipment and/or transport and hence the number of field teams that can be simultaneously active; unusual weather conditions may make some areas unexpectedly (temporarily) inaccessible (in addition to normal seasonal effects); public or religious holidays may not have been taken into account or team members may become ill or have unforeseen family commitments. If there is to be an extended break in data collection it is important to provide field teams with refresher training, if required. If changes in the work plan become necessary, then the key elements of the survey design should be maintained.

### Box 4.1: Worked example - Clusters by technology type and broad area

As shown below, survey design for the *Republic Osmiga* led to selection of 77 clusters, i.e. 28 for utility supplies, 30 for borehole/tubewell supplies and 19 for protected springs. The clusters are split between the three broad areas A, B and C. Thus, as one cluster is equivalent to one week's work for a field team, the survey for the *Republic Osmiga* required a minimum of 77 field-team weeks for data collection. To ensure that the survey was completed within a 4-5 month period, the national team decided to employ a total of four field teams for the rapid assessment project meaning that each team would cover approximately 19 clusters.

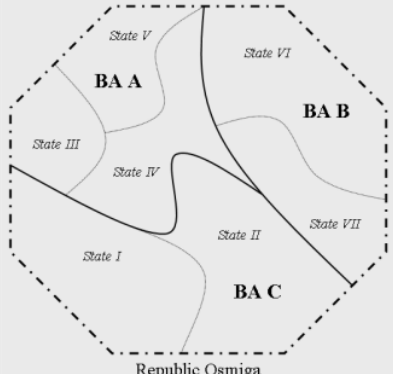
	Technology category	Broad area A	Broad area B	Broad area C	Total Republic
	Utility-piped supplies: Clusters required	11	13	4	<b>28</b>
Boreholes/ tubewells: Clusters required	5	13	12	<b>30</b>	
Protected springs: Clusters required	2	6	11	<b>19</b>	
All technologies: Clusters required	<b>18</b>	<b>32</b>	<b>27</b>	<b>77</b>	

### Box 4.2: Worked example - Developing a work plan

The RADWQ management team of the *Republic Osmiga* decided to plan for an initial two-week period where all four teams are based in broad area C and, between them, cover a total of eight clusters, comprising four utility-piped supply clusters, two borehole/tubewell clusters and two protected spring clusters. At the end of the initial two weeks, the management team planned for a one day meeting at which all field team staff had the opportunity to exchange experiences and to agree on harmonised procedures.

Following this initial period the teams will complete the remaining clusters as follows:

- **Team 1:** Remaining 19 clusters in BA C (ten borehole/tubewells and nine protected springs);
- **Team 2:** 16 clusters in BA B (seven utility-piped supplies, six borehole/tubewells and three protected springs);
- **Team 3:** 16 clusters in BA B (six utility-piped supplies, seven borehole/tubewells and three protected springs);
- **Team 4:** 18 clusters in BA A (11 utility-piped supplies, five borehole/tubewells and two protected springs).

Teams 2 and 3 have fewer weeks in the field than Teams 1 and 4 but this could allow them to assist with data analysis (e.g. checking computer entries correlate with paper records, reviewing quality control readings) or to assist other teams in completing the remaining clusters.

In the survey design, six clusters were selected for protected springs in broad area B (see Box 4.1). These were allocated, by proportional weighting, to five of the nine districts: one cluster from each of districts 2, 5, 7 and 9, and two clusters from district 6 (see Box 3.4). Each cluster consists of 15 samples (cluster size) for which collection and analysis should be completed in one week.

If three of these six clusters for protected springs are assigned to Team 2 then travel considerations suggest that it is efficient to assign the clusters in districts 2 and 7 plus one cluster from district 6 (rather than assign clusters in districts 2, 5 and 9, for example). The remaining three clusters from districts 5, 6 and 9 were assigned to Team 3.

Applying this approach to assignment of utility-piped water and borehole/tubewell clusters in broad area B and adopting an initial two-week period where all teams work in broad area C, a possible work plan for Teams 2 and 3 is shown in the table below (respective work plans for Teams 1 and 4 are not shown here but need to be prepared accordingly).

As reflected in the work plan below, the national team decided to accommodate two one-week breaks during the field implementation period: one week working break for a mid-term meeting of all the teams in the capital to monitor progress and make revisions to the work plan, if needed; and one week leisure break during the national holidays where team members could visit their families. Thus, in total the field implementation period for Teams 2 and 3 is 20 weeks.

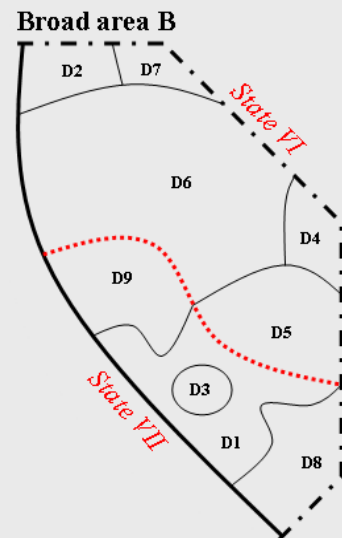

<b>Box 4.2 (continued)</b>		
<b>Work plan for Teams 2 and 3</b>		
<b>Week</b>	<b>Team 2</b>	<b>Team 3</b>
1	Utility-piped supply cluster: BA C district 4	Utility-piped supply cluster: BA C district 4
	JOINT MEETING OF ALL FIELD TEAMS TO REVIEW IMPLEMENTATION OF WEEK 1	
2	Borehole/tubewell cluster: BA C district 4	Protected spring cluster: BA C district 4
	JOINT MEETING OF ALL FIELD TEAMS TO REVIEW IMPLEMENTATION OF WEEK 2	
3	Travel to BA B district 2 Protected spring cluster: BA B district 2	Travel to BA B district 5 Protected spring cluster: BA B district 5
4	Borehole/tubewell cluster: BA B district 2	Borehole/tubewell cluster: BA B district 5
5	Utility-piped water cluster: BA B district 2	Borehole/tubewell cluster: BA B district 5
6	Utility-piped water cluster: BA B district 2 Travel to district 7	Borehole/tubewell cluster: BA B district 5
7	Protected spring cluster: BA B district 7	Utility-piped water cluster: BA B district 5 Travel to district 8
8	Borehole/tubewell cluster: BA B district 7 Travel to review meeting	Borehole/tubewell cluster: BA B district 8 Travel to review meeting
9	JOINT MID-TERM REVIEW MEETING OF ALL FIELD TEAMS	
10	Travel to district 4 Borehole/tubewell cluster: BA B district 4 Travel to district 6	Travel to district 1 Borehole/tubewell cluster: BA B district 1
11	Borehole/tubewell cluster: BA B district 6	Borehole/tubewell cluster: BA B district 1 Travel to district 9
12	Borehole/tubewell cluster: BA B district 6	Protected spring cluster: BA B district 9
13	Borehole/tubewell cluster: BA B district 6	Utility-piped water cluster: BA B district 9
14	Protected spring cluster: BA B district 6	Utility-piped water cluster: BA B district 9
15	Utility-piped water cluster: BA B district 6 Travel home	Borehole/tubewell cluster: BA B district 9 Travel home
16	LEISURE BREAK (NATIONAL HOLIDAYS)	
17	Travel to district 6 Utility-piped water cluster: BA B district 6	Travel to district 6 Protected spring cluster: BA B district 6
18	Utility-piped water cluster: BA B district 6	Utility-piped water cluster: BA B district 6
19	Utility-piped water cluster: BA B district 6	Utility-piped water cluster: BA B district 6
20	Utility-piped water cluster: BA B district 6	Utility-piped water cluster: BA B district 6

### **4.3 Preparation for field work**

#### **4.3.1 Training**

The management team or the field coordinator should organise a practice-oriented training programme, in classroom and in the field, for all field team staff which is specifically designed for the purposes of the RADWQ survey and which ensures consistency in field work within and amongst teams. The training can be linked to development of the work plan as, during the training, teams will be able to determine the time needed for analysis of the selected parameters and based on their previous field experience, to advise on travel times both within and between clusters. The main elements of the training should be:

- objectives of the survey (see Chapters 1 and 2);
- basic introduction to the core elements of the survey design and the specific results for the country (see Chapter 3);
- parameter selection and sampling frequency of individual parameters (see Chapters 5 and 7);
- sample point selection for point sources, utility-piped supplies and, if required, households within an identified sampling unit (see Section 4.3.2 and Chapter 3), including selection of

sampling sites where inadequate information was available to identify specific sites when selecting clusters and/or drawing up the work plan;

- sample collection and, if required, storage procedures (see this section and existing literature, such as WHO (1997) and Bartram and Ballance (1996));
- analytical methods for the core and, if required, additional indicators/parameters (microbial, chemical and physical) using the field equipment (see this section plus supporting information in Chapters 5 and 7), including the preferred order of indicator/parameter testing (see Section 4.3.5);
- need for collecting any rubbish generated during field work (i.e. packaging of consumables, used tissues etc.) and procedures for disposing of them;
- quality control procedures, including use of aseptic techniques (see Section 4.4 and Annex 3);
- sanitary inspections for all water supply technologies included in the survey (see this section plus supporting information in Chapter 6 and Annex 2);
- data recording and reporting requirements in the field, including procedures for the proper assignment of unique alphanumeric identification codes to water supplies included in the assessment (see Section 4.3.6 plus supporting information in Chapter 8 and Annex 4); and
- communication with and involvement of local community members on the occasion of the field visits (e.g. joint reading of water quality results, provision of on-site advice in response to shortcomings identified during sanitary inspection or distribution of pre-prepared education materials).

#### **4.3.2 *Sample point selection within clusters***

Before field work commences, it is important that clear procedures are established and understood by the field teams on how to identify the location of sampling points within the allocated clusters and where to physically take the water sample. The following approach is recommended:

- point sources (i.e. protected springs, protected dugwells, boreholes/tubewells) are tested at the source (e.g. spring outlet, pump outlet);
- piped supplies are tested at the clearwater tank at the water treatment works (if present), at service reservoirs and at various representative locations in the distribution system. The exact number of samples is determined by the size of the system and the cluster size, as illustrated by the example in Box 4.3; and
- household supplies are tested either at the tap (e.g. in piped supplies) or at the storage container (e.g. for point sources and vehicle/tanker supplies); see Box 4.5 for sampling steps. If water piped into the household is still stored (e.g. for times when the supply of water supply is interrupted), the water sample is best taken from storage containers. Note that this particular issue goes beyond the primary objective of RADWQ which is testing the quality of “improved” drinking-water sources, and that the testing of water storage containers has more to do with domestic hygiene than with the quality at the source.

Sample locations are usually obvious for point sources and household supplies, but where detailed information on the location of individual point sources within a sampling unit is not available, on-site decisions need to be made by the field teams, after seeking advice from local people. The practical considerations for sample point selection in utility-piped systems, especially in large ones, can be more demanding for the field teams. If possible, local contact persons, who can assist the team in locating sampling points, should be identified and contacted prior to practical field work (or approximately two weeks before arriving in a district).

Box 4.3 provides an example that illustrates allocation of sampling points that are representative for a utility-piped water supply. For identifying the actual sampling points in a distribution system from



where the water sample is physically taken, preferably official inspection taps should be used (i.e. taps that are either in place for routine operational monitoring by the supplier or for water quality testing by the agency responsible for water supply surveillance). In any case, advice should be sought from the operator of the system to locate these taps. In situations where inspection taps are absent or not present in sufficient numbers, nearby public or yard taps directly connected to the distribution system can be chosen as surrogate sampling points. Household taps in buildings can also be used as a surrogate sampling point provided they are directly supplied from the mains. If household taps are used as sampling points for the distribution system, it is important to note that these samples are not part of the household sampling, which is carried out in addition to the overall water supply sampling.

**Box 4.3: Worked example - Allocation of sampling points for utility-piped water supplies**

In this example, the utility-piped supply serves a population of 260,000. For the purposes of RADWQ, this supply can be subdivided into units, each having a population of 5,000. Each unit is considered to be equivalent to a single water supply (see Section 3.1.2). Thus, this example the utility-piped supply is equivalent to 52 (= 260,000/5,000) water sources.

According to the survey design, one cluster comprising 40 water sources is to be chosen from this utility-piped supply. To identify individual sample points, which are statistically representative, the supply system can be subdivided into four principal service zones (i.e. red, green, blue and purple), as shown in the top figure. Each service zone is supplied by a particular service reservoir (SR) or, in the case of the green zone, directly by the water treatment works (WTW). It is important to note, however, that if the supply system had more than one source, this also would need to be reflected when subdividing the system. Alternatively, if the system was supplied by one source and one service reservoir only, the subdivision could be guided by the proportion of the population living in various city boroughs, for example.

Service zone	Population	Equivalent supplies	Proportion	Proportionally allocated sample points
Red	15,000	3	5.8 %	2
Green	45,000	9	17.3 %	7
Blue	50,000	10	19.2 %	8
Purple	150,000	30	57.7 %	23
Total	260,000	52	100.0 %	40

As detailed in the table above and the top figure, each service zone has differing populations that can be equated to a number of water supplies (i.e. using the formula 1 supply ~ 5,000 population). The 40 sample points that comprise one cluster can then be proportionally allocated to the service zones to ensure representative coverage of the whole system (as shown in the last column of the table above). The proportional allocation of sample points to particular service zones provides a simple basis for the representative selection of sampling points in a utility-piped supply.

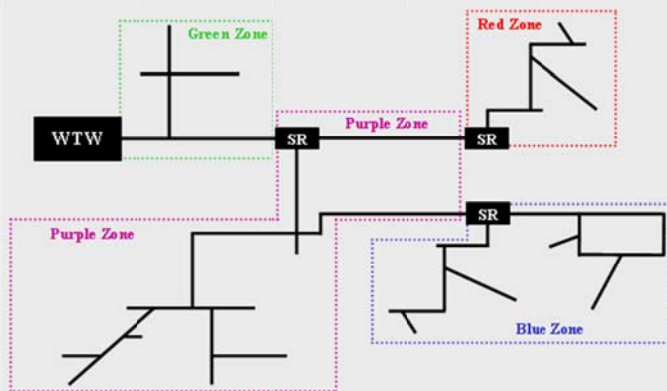

An example of selecting representative sample point locations within one of the service zones (blue) is shown in the bottom figure. Note that the sampling points include the SR and a spread of points within the distribution system (including pipe end points).

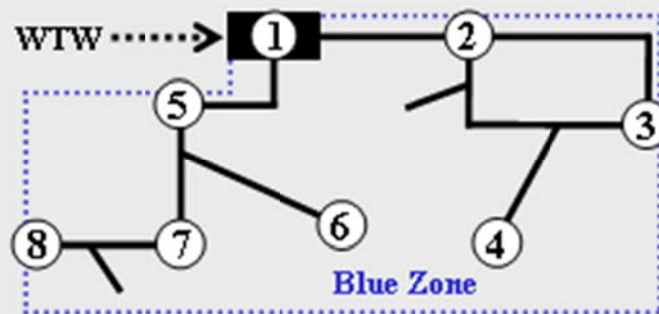

Household sampling is an integral part of RADWQ programmes. Household samples are not part of the sample size for water supplies, but are taken in addition to it. Household water should not be tested in every community where a water supply is tested but only in a sample of communities (see Section 3.1.3 for details). Box 4.4 provides an example that illustrates allocation of household sampling points that are representative for both technology type and broad area in the *Republic Osmiga*.

<b>Box 4.4: Worked example - Allocation of household sampling points</b>				
For the <i>Republic Osmiga</i> , allocation of the 160 household samples (= 10% of the overall sample size for water sources) needs to be representative of the 3 technology types and, ideally, the 3 broad areas. Using the same data as for secondary stratification (see Box 3.2), the household samples could be allocated as given in the table below. In developing the work plan, the field coordinator, together with the field teams, needs to decide and establish procedures how to allocate these samples. They could be spread amongst the clusters (e.g. approximately one per cluster for protected springs and boreholes) or could be taken in a single cluster or in a limited number of clusters (i.e. for each technology and broad area). In all cases data collected from households must be linked to that for the water point.				
<b>Technology category</b>	<b>Broad area A</b>	<b>Broad area B</b>	<b>Broad area C</b>	<b>Total Republic</b>
Utility-piped supplies	40 (= 40%)	50 (= 50%)	10 (= 10%)	100 (= 100%)
Boreholes and tubewells	8 (= 20%)	19 (= 50%)	11 (= 30%)	38 (= 100%)
Protected springs	2 (= 10%)	9 (= 40%)	11 (= 50%)	22 (= 100%)
All technologies	50 (= 31%)	78 (= 49%)	32 (= 20%)	160 (= 100%)

Household water will only be tested in communities where a water source is included within the assessment. When selecting individual households during field implementation it is therefore important that field teams confirm with household members visited that the water consumed matches that from the source included in the assessment and not from other sources in the vicinity. For piped supplies, field teams need to confirm with local operational staff that the households selected receive their water from the section of the distribution system from where the corresponding source water sample was taken.

When visiting households which receive piped water, field teams need to find out from household members if the water that comes from the tap is mainly used directly from the tap or if it is permanently or temporarily stored in containers before consumption (i.e. in settings where the supply is intermittent). In situations where the water is commonly stored before consumption, the water sample is best taken from storage containers and not from taps. Respective explanatory notes should be given in the field record sheet.

### **4.3.3 Sanitary inspections**

Sanitary inspections are discussed in detail in Chapter 6. They require field teams to use observation to identify, assess and record the potential risks and possible pollution problems that may threaten drinking-water quality at the source, point of abstraction, treatment works or distribution system. Sanitary inspections can be carried out for all types of water supply (e.g. spring, well or borehole) and all supply steps (e.g. abstraction, treatment, distribution, storage, households).

For basic/initial RADWQ programmes, a set of sanitary inspection standard forms have been developed (see Annex 2). When carrying out a sanitary inspection, the analyst should

- visit the facility, and look at the surrounding area;
- choose the most suitable sanitary inspection form;
- answer each question on the sanitary inspection form (note that some risks will be on-site whilst others may be off-site);
- seek information from local people, if necessary;

- add up the number of questions having the answer “Yes” to calculate the sanitary inspection risk score; and
- if time allows, provide short on-site feedback to community member in response to sanitary risks identified.

Sanitary inspection questions are written in such a way that the answer to any question is “Yes” if a risk exists. Thus, the phrasing of some questions may appear to be rather clumsy, because questions are intended to identify protective features that are missing. The recommended forms provided in Annex 2 have ten questions each, so the scoring range used is from 0 to 10 or 0-100%. The minimum and maximum sanitary risk score categories are, respectively, 0-2 (low risk) and 9-10 (very high risk). For basic/initial assessments it is recommended that risk factors are not ranked in order of priority and receive equal weighting.

Whilst the standard forms provided in Annex 2 have been developed for basic/initial assessments, ideally they need to be customised for every technology within each country. It is therefore recommended that the management team reviews the set of suggested sanitary inspection forms prior to the survey, possibly together with external environmental health and water quality experts, to confirm that the questions in the forms are clearly written, actually relevant and reflect the water supply situation (e.g. in terms of design codes, protective features, construction or maintenance practices) in the country or, if not, to modify the forms accordingly.

Laboratory-based staff may have limited experience in carrying out sanitary inspections. Therefore, they will require training on sanitary inspections prior to the survey with some practical exercises in the field that include visits at all types of water supply and all supply steps to be included in the RADWQ. For example, during the pilot study many analysts were unfamiliar with water treatment works so including a visit to one during the training programme assisted with assessment of sanitary risks as well as with selection of sampling points. Proper training ensures that field teams develop a common understanding on the different questions and risk factors covered by the sanitary inspection forms; thus, training minimises the possible subjective nature of data collected and increases comparability of the results amongst field teams. Also, the training exercise gives field teams the opportunity to assess whether individual questions in the forms are easy to understand. This feedback will be valuable to improve the sanitary inspection forms and to increase their clarity for field team staff.

#### ***4.3.4 Sample collection and storage***

The second edition of the WHO Guidelines for Drinking-Water Quality (WHO 1997) and Bartram and Ballance (1996) provide detailed information and illustrations on sample collection for different water sources. This information is summarised in Box 4.5 for wells and storage tanks as well as for taps and pump outlets.

The volume collected depends on the range of variables and analytical methods included in the survey. Samples for microbial and chemical analysis should be collected in separate bottles but at the same time.

For basic/initial RADWQ, as discussed in Chapters 5 and 7, it is recommended that field testing kits be used for all microbial, physical and chemical analysis. The use of field methods on-site has the general advantage that samples do not need to be conserved, stored and transported prior to analysis. However, if the management team decides to analyse (part of the) samples in central laboratories, proper sample preservation and storage procedures need to be established. For microbial analysis, a sufficient number of sterile sample bottles need to be available and, if chlorinated water is being collected, sodium thiosulphate needs to be added to the sample bottles to

neutralise the chlorine. During transport, samples always need to be stored in a clean, cool and dark environment to protect them from deterioration and recontamination. Samples should preferably be analysed within the same working day. If the delay between sample collection and analysis is less than 6 hours, samples can be kept at ambient temperatures but not exceeding 25 °C. If the delay is between 6-18 hours samples need to be chilled to about 5°C (with a tolerance range of  $\pm 3^\circ\text{C}$ ) with ice packs in an insulated container or cool bags. If proper preservation and storage measures cannot be met, it is unlikely that the analytical results reflect the bacteriological condition at the time of sampling. Also for physical and chemical parameters, proper preservation and storage procedures need to be followed. Further details on minimum requirements on sample preservation and storage for microbial, physical and chemical parameters, including information on additional equipment needed for preservation, storage and transport of samples, can be found in Bartram and Ballance (1996).

The procedures for sample collection, preservation and storage need to meet the minimum requirements noted above and must be applied consistently amongst all field teams as otherwise the water quality results will not be comparable. The training of field staff therefore needs to address these issues.

#### Box 4.5: Taking samples

*Taking a sample from a tap or pump outlet:*

- Step 1:** Remove any attachments and clean the tap or outlet with a dry and clean cloth.
- Step 2:** Run the tap or pump at maximum flow for one minute (if possible do not let the water go to waste, especially in water-scarce areas). *Note:* It is advised that the tap or outlet is not sterilised (e.g. flamed) because in RADWQ information on the quality of the water as consumed is sought. *Note:* Collect the first litre without flushing if metals like lead or copper are included in the assessment.
- Step 3:** Collect the sample from the running tap or outlet in a sterile container or bottle.
- Step 4:** Analyse immediately or store sample in a cool and dark environment if the delay between sample collection and analysis is less than six hours. If the delay > six hours, chill to about 5°C.



*Taking a sample from a well or storage tank*

*(in case the sample cannot be taken from a tap or pump outlet):*

- Step 1:** Flame the sample cup (used for membrane filtration) with methanol (or ethanol) or use a sterile container or bottle. Attach a string and clean weight.
- Step 2:** Lower the sample cup or collection bottle into the well or tank and fill it by immersing it well below the surface making sure that it does not touch the sides or disturbing any sediment.
- Step 4:** If more than one collection is needed, then transfer the water to a sterile container.
- Step 5:** Analyse immediately or store sample in a cool and dark environment if the delay between sample collection and analysis is less than six hours. If the delay > six hours, chill to about 5°C.



### 4.3.5 Practical planning issues

As discussed in the previous chapters, it is recommended that for basic/initial surveys all water quality testing is carried out in the field using appropriate field equipment. The field team staff may be more experienced in laboratory-based analysis and would, therefore, benefit from a training programme on use of the field equipment selected for the survey. Learning how to apply aseptic techniques in the field (as opposed to a laboratory; see also Section 4.4) would be an important component of such training. In addition to the use of the equipment the programme should include practical field work exercises, ideally where the teams take full responsibility for planning all aspects of the work.

The training programme will enable teams to develop mechanisms for sharing in the preparation of equipment, consumables, transport etc. before starting the survey proper. This preparation, together with joint debriefing sessions after the field work should enable the teams to develop and refine useful checklists assisting in every-day planning and preparing field work such as the examples given in Box 4.6; further example checklists developed during the RADWQ pilot studies are provided in Annex 5.

<b>Box 4.6: Examples of checklists for field implementation teams</b>	
<p><i>Top tips check list:</i></p> <ul style="list-style-type: none"> <li>– Find a flat area</li> <li>– Find the shade/shelter</li> <li>– Have a bag or container for storage of waste materials</li> <li>– Follow aseptic procedures (see Annex 3)</li> <li>– Reduce usage of methanol by sterilising:               <ul style="list-style-type: none"> <li>▪ tweezers with lighters or ethanol</li> <li>▪ Petri dishes in autoclave, steam steriliser, household pressure cooker or cooking pot</li> </ul> </li> <li>– Have a list stating what photometer wave length should be used for each parameter</li> <li>– Always use sample blanks</li> <li>– Remember to include quality control samples</li> </ul>	<p><i>Morning check list:</i></p> <ul style="list-style-type: none"> <li>– Check completeness of main equipment and consumables, record sheets and any extra items (as listed in checklists in Annex 5)</li> <li>– Check completeness of sanitary inspections forms for the day's number of visits</li> <li>– Calibrate conductivity meter every morning</li> <li>– Calibrate pH meter every morning</li> <li>– Calibrate turbidity meter every morning</li> <li>– Prepare sufficient amount of media for the day's number of samples</li> <li>– Prepare sufficient number of sterilised Petri dishes for the day's number of samples and dispense the media pads</li> </ul>

Each team will require the appropriate equipment, consumables and sanitary inspection and record forms to be able to undertake the assessment at their allocated clusters. Also, the field teams will need to prepare and manage their transport and accommodation arrangements in liaison with the field work coordinator. If possible, accommodation for field teams should be pre-booked prior to their departure to save them spending unnecessary time locating lodgings. Suitable accommodation would need to provide a reliable power supply for recharging the incubator batteries, access to distilled/deionised water (possibly through the local water supplier, hospital or a health laboratory) and opportunity for safe disposal of used chemicals and microbial wastes.

The on-site training sessions will provide the data needed to estimate the time required by a field team to complete analysis of all the parameters included in the survey at a single sampling point. This will vary with the number of parameters and also the size of the team and amount of equipment available. The time will also reduce as the team members gain experience and confidence in use of equipment in the field. In the RADWQ pilot studies, the average time required by following the testing order suggested in Figure 4.1 was one hour (at the end of the training programme) where

- teams had a minimum of two people, one analyst being responsible for testing of microbial and related parameters (i.e. thermotolerant coliforms, chlorine residuals, turbidity and pH)

and for carrying out the sanitary inspections, the other analyst being responsible for testing of physico-chemical parameters;

- each team had one set of field testing equipment;
- analysis was for thermotolerant coliforms and for the core physico-chemical parameters suggested in Table 2.2 (plus copper as optional parameter); and
- sanitary inspections were carried out at every site.

It is important to have a good estimate of this time early in the survey design as it determines the cluster size, together with travel time between sampling points. Good management within the teams and allocation of responsibilities for specific analyses helps to keep this time to a minimum, allowing for larger cluster sizes. However, the estimates need to be realistic as otherwise the cluster sizes will be too large, placing undue stress on the teams when they are out in the field and trying to comply with the work plan.

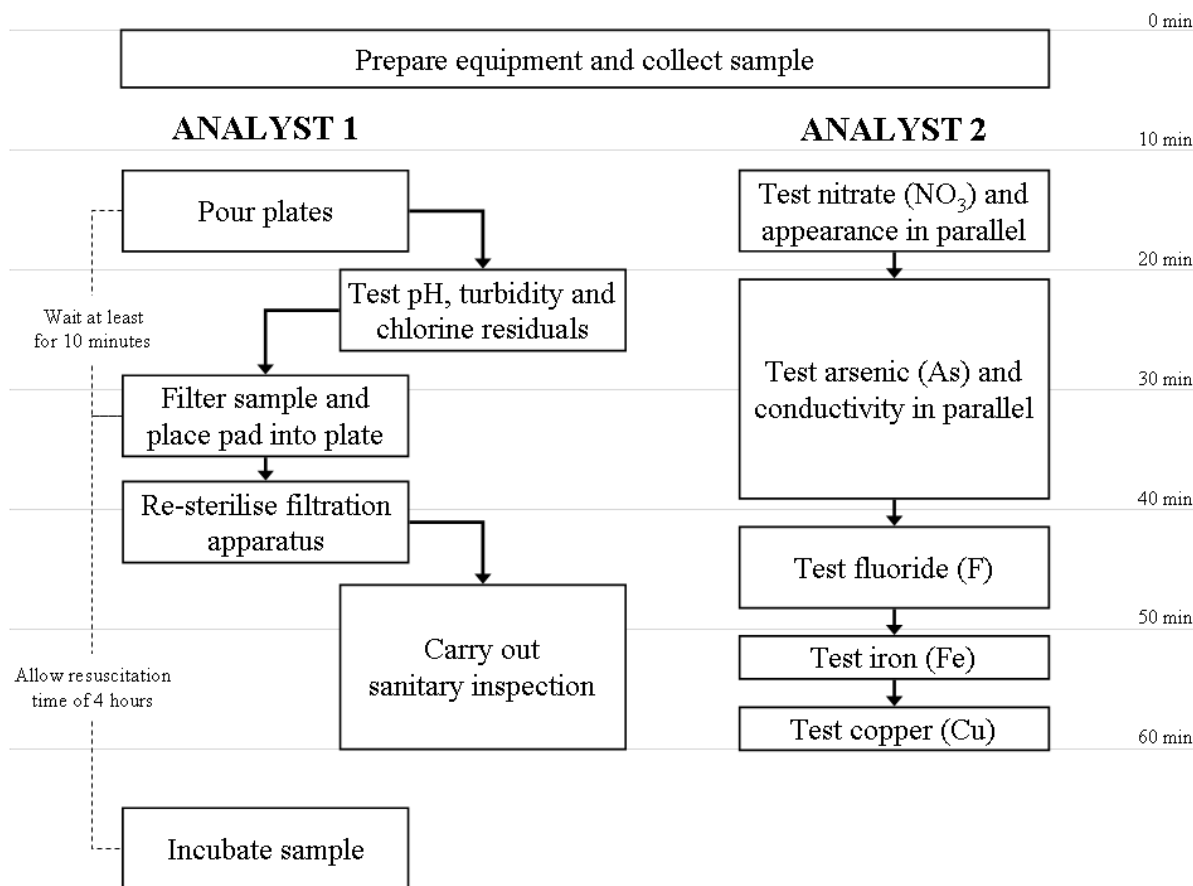

Figure 4.1: Order of testing in RADWQ pilot studies

#### 4.3.6 Recording the results

Prior to commencing the field work, recording procedures and all the forms for recording data need to be agreed. It is common to have separate sheets for recording water quality results (see Annex 4) and sanitary inspections (see Annex 2). In addition, it is recommended that every field team member keeps a daily logbook. Results can be recorded in paper sheets or, where resources and expertise allow, in electronic format in personal digital assistants or cell phones. In case that samples will be sent to the laboratory for analysis, chain-of-custody forms need to be used tracking

a samples record (i.e. when and by whom the sample was collected, when and by whom the sample was received at the lab and what time and by whom the laboratory analysis was conducted).

The results of each day's sampling should be carefully recorded in the forms and the logbooks. It is critical that the cluster name (or number) is clearly marked on all forms and that the date, name of analyst, community visited and sample sites are also clearly recorded. The completed sanitary inspection forms for each day's activity should be fixed to the back of the daily report sheets and the forms kept in a folder. According to the procedures agreed, the data should periodically be sent (e.g. at the end of each week's sampling) by courier, speed post, fax or email to the field work coordinator to be put into the computer database, and the forms filed. In some countries it may be routine for field analysts to have access to a computer in the field for data entry. If this is the case the time taken for this should be included when constructing the work plan. However, there needs to be a back-up copy of the data entered (i.e. forms and/or logbooks).

Prior to commencing field work it is important that a clear alphanumerical identification code is established which assigns a unique water source scheme number (WSS-number) to individual sources included in the assessment and which provides clear information on the broad area and cluster from where the sample was collected. An example of such a coding system is provided in Box 4.7. As it is vital that the field teams have fully understood the identification code and that WSS-numbers are assigned and reported properly, this issue should be thoroughly addressed during the training.

**Box 4.7: Identification code used in RADWQ pilot studies**

In the RADWQ pilot studies, the unique WSS-number was 8 characters and allocated as follows:

- Characters 1-3: Country code
- Character 4: Broad area code
- Characters 5-6: Cluster number
- Characters 7-8: Sample number within the cluster

For example, the WSS-no. "ROS51207" indicates the 7<sup>th</sup> sample within cluster 12 of broad area 5 in the *Republic Osmiga* (ROS).

#### **4.4 Analytical quality control**

Quality control requires careful consideration of a number of aspects of the analytical process. There are a number of key terms that are commonly used in relation to quality control, such as precision, reliability and accuracy. In terms of basic/initial rapid assessments, the principal focus will be on precision - that is the degree to which two tests performed on the same sample agree with each other. Measures of accuracy and reliability become more feasible in higher level assessments when more data are available.

As analytical quality control is an integral part of field work, it is important that this issue is adequately addressed during the training and that field staff fully understand the respective procedures which are discussed in the sections below.

##### **4.4.1 Microbial analysis**

Analytical quality control is important in microbial testing. Microorganisms, unlike chemicals, are discrete particles and, therefore, are always non-randomly distributed within a water sample. In unmixed samples this may be exacerbated as they are likely to be found in "clumps". Therefore it is important that immediately before analysis, the samples are thoroughly mixed. The organisms in a well-mixed sample will be better distributed as discrete particles through the water, with some

under-dispersion where clumping remains, but still non-random. Therefore sub-samples will inevitably contain different numbers of organisms. If replicate counts using these sub-samples give different results there is no way of knowing whether this is correct and due to random variation, or incorrect due to analytical errors.

The most important way to assure the quality of data generated in the field is that each analyst uses a good aseptic technique. Annex 3 provides a checklist of key aseptic techniques to be considered during field work. It is vital that the training of field staff specifically addresses aseptic techniques as part of overall quality control procedures and that field staff have fully understood all required procedures. Aseptic technique evaluation should be performed on a regular basis throughout the assessment by the field teams using a simple form provided in Annex 3. This should be supplemented by an evaluation by the field work coordinator during his/her visit(s) to each team during the assessment. For basic/initial assessments it is recommended that aseptic technique evaluation forms are to be completed at least bi-weekly in the field.

Equally important for assuring the quality of results are regular checks on the incubator temperature which can be easily performed on most water testing kits. Some have a real-time digital display and in others temperature must be checked following a separate process. Also, it is recommended that more than one person counts colonies for each sample in order to avoid any counting errors.

For quality control of microbial analyses in basic/initial assessments a duplicate, split-sample approach is recommended. For any single result, a range of acceptable values from a second analysis (split sample) can be defined based on a Poisson distribution of bacteria within the water samples. In this approach, a 200 ml sample is mixed thoroughly and then divided into two 100 ml sub-samples. The count from the first sample is recorded and the 95% confidence limit for the second (paired) count is recorded from the quality control chart for microbial tests (as provided in Annex 3). The count from the second sample is then recorded alongside and if this falls outside the confidence intervals this is highlighted. Some typical acceptable results are shown below in Box 4.8. For basic/initial rapid assessments, it is recommended that a split-sample is done on one microbial sample per day as a quality control check. Quality control readings should be recorded separately from the assessment results. Annex 3 provides an example of a weekly record sheet for parameter quality control readings.

It should be stressed that a pair of results where the second is outside the 95% confidence limits do not indicate contamination of the sample and the results should not be rejected as they are not necessarily false, rather they are outside the predicted density derived from a statistical model. In routine assessments re-sampling would probably be required, but is usually not an option in rapid assessments as field teams will have either moved to different locations before results are available and/or have insufficient flexibility within the programme to return to such sites. This aspect should be reflected in any analysis of microbial data.



**Box 4.8: Worked example – Quality control for microbial analysis**

In the table below, all seven second samples are within the 95% confidence interval so these quality control data indicate a high level of confidence for microbial results taken during this period. It is still advisable to check whether the same analyst did all the testing. If different analysts did the testing then this provides quality assurance on the skills of the team(s).

Quality control samples Team B – Month 1	Split sample 1 (TTC/100 ml)	95% confidence value (TTC/100 ml)	Split sample 2 (TTC/100 ml)	Comment
B1.1	<2	0-7	3	OK
B1.2	<2	0-7	<2	OK
B1.3	4	0-12	<2	OK
B1.4	3	0-11	2	OK
B1.5	<2	0-7	<2	OK
B1.6	<2	0-7	<2	OK
B1.7	<2	0-7	<2	OK

In the table below, the results of the data set for month 4 are so variable and differ considerable from month 1 data for team B that they do not give a high level of confidence in the microbial data and/or the analyst's performance, and therefore they need investigation. This should include aspects such as the analyst's performance (e.g. check of aseptic technique report forms), sample conservation measures between collection and analysis of samples, functioning of incubators (e.g. incubation temperature) and the condition of consumables.

Quality control samples Team B - Month 4	Split sample 1 (TTC/100 ml)	95% confidence value (TTC/100 ml)	Split sample 2 (TTC/100 ml)	Comment
B4.1	62	42-86	51	OK
B4.2	54	35-77	84	Not OK: 2 <sup>nd</sup> sample is too high (or 1 <sup>st</sup> sample is too low)
B4.3	<2	0-7	17	Not OK: 2 <sup>nd</sup> sample is too high (or 1 <sup>st</sup> sample is too low)
B4.4	39	23-59	55	OK
B4.5	78	55-105	TNTC	Not OK: 2 <sup>nd</sup> sample is too high (or 1 <sup>st</sup> sample is too low)
B4.6	TNTC	-	43	Not OK: 2 <sup>nd</sup> sample is too low (or 1 <sup>st</sup> sample is too high)
B4.7	82.6	58-110	68.2	OK but the reporting of fractional counts needs to be queried as it is atypical and suspect.

#### 4.4.2 Physico-chemical analysis

Analytical quality control is most easily achieved for the chemical parameters by using a split sample approach. A reasonable level of precision for these assessments is 90% compliance - that is, the result of the second tests should be within 10% above or below the first result. This is calculated by dividing the difference between the two results by the first result. The equation to calculate precision and some typical results are shown in Box 4.9. If the result is outside of the 90% compliance margin, these data should be marked as suspect. In this case, if time and consumables allow, field teams should repeat the analysis. In overall data analysis, if, for example, less than 10% of analytical quality control data fall outside the 90% compliance margin then all suspect data should be discarded for analysis. If many data are suspect, then all the data should be analysed, but the report must highlight the quality control problems and therefore the potential limitations in any conclusions drawn.

For basic/initial RADWQ programmes it is recommended that analytical quality control for every physico-chemical parameter is carried out on the same sample once per week. Quality control

readings should be recorded separately from the assessment results. Annex 3 provides an example of a weekly record sheet for parameter quality control readings.

<b>Box 4.9: Worked example – Quality control for chemical analysis</b>				
The precision is calculated according the following formula (note that if result 2 is higher than result 1 the negative difference between them does not affect the calculation of precision):				
Precision (%) =  (result 1 – result 2)/result 1  x 100				
<b>Quality control samples Team B – Month 1</b>	<b>Split sample 1 (mg/l)</b>	<b>Split sample 2 (mg/l)</b>	<b>Precision</b>	<b>Comment</b>
B1.1	2.3	2.3	$=  (2.3 - 2.3)/2.3  \times 100$ = 0%	The results are identical (i.e. within the 10% compliance range) and therefore acceptable
B1.2	2.4	2.6	$=  (2.4 - 2.6)/2.4  \times 100$ = 8.33%	The results are within the 10% compliance range and therefore acceptable
B1.3	0.16	0.15	$=  (0.16 - 0.15)/0.16  \times 100$ = 6.25%	The results are within the 10% compliance range and therefore acceptable
B1.4	0.15	0.17	$=  (0.15 - 0.17)/0.15  \times 100$ = 13.33 %	The results are outside the 10% compliance range and therefore unacceptable; repeat analysis if time and consumables allow
B1.5	47	43	$=  (47 - 43)/47  \times 100$ = 8.51%	The results are within the 10% compliance range and therefore acceptable
B1.6	33	31	$=  (33 - 31)/33  \times 100$ = 6.06%	The results are within the 10% compliance range and therefore acceptable
As shown in the table above, only one of the results is outside the 10% precision (90% compliance) range. If all chemical control samples show a similar pattern this indicates a high level of confidence for chemical results taken during this period. It is still advisable to check whether the same analyst did all the testing. If different analysts did the testing then this provides quality assurance on the skills of the team(s).				

## 5 MICROBIAL QUALITY MONITORING

There are a wide variety of micro-organisms that may be found in water. These include some that are pathogenic and others that are not pathogenic. Some of the non-pathogenic micro-organisms may lead to other problems in water supplies such as taste and odour, which may be of particular importance to users of the supply as an indicator of perceived safety and may influence their selection of water for consumption. However, the principal concern for microbial quality is the potential contamination by pathogens. They can be classified according to their group or family and include viruses, bacteria, protozoa, and helminth eggs or larvae.

Infectious diseases caused by these pathogenic organisms are the most common and widespread health risk associated with drinking-water (WHO, 2011a). However, drinking-water is only one way for the transmission of such pathogens; some agents may be transmitted from person to person, or through the contamination of food. The risk of acquiring a waterborne infection increases with the level of contamination by pathogenic micro-organisms. Yet, the relationship is not simple and depends on factors such as infectious dose and host susceptibility.

Faeces are an important source of many pathogens. In general terms, the greatest microbial risks are associated with ingestion of water that is contaminated with faeces from humans or animals (Dufour *et al.*, 2012). Therefore, monitoring of microbial drinking-water quality is the most important aspect from a public health perspective.

The pathogens that may be transmitted through contaminated drinking-water are diverse in characteristics, behaviour and resistance. Table 5.1 provides an indication of the range of different pathogens for which there is some evidence of public health significance related to their occurrence in drinking-water supplies.

### 5.1 *Indicator selection for rapid assessments*

Although it is known that pathogens cause disease, the routine monitoring of pathogens is generally not undertaken for several reasons. For many pathogens there is a lack of analytical tools available, and where these do exist they are often expensive, time-consuming and difficult to perform. Individual pathogens cannot be guaranteed to be present in all untreated or unprotected waters as this depends on whether they have been released (usually from the faeces of an infected person) into the water. Therefore failure to observe a particular pathogen cannot be taken to imply an absence of other pathogens. Furthermore, it is desirable to have a means of detecting contamination before there is a presence of pathogens in order to ensure actions can be taken to prevent a major outbreak of disease. However, in countries where resources permit, assessments of pathogen presence in source and drinking-water are a useful tool in determining the public health risk from drinking-water and in developing health-based water quality targets. In RADWQ, pathogen assessments may only be considered under higher level assessments.

In relation to basic/initial RADWQ, for assessing microbial drinking-water quality the following core indicators are recommended:

- *Thermotolerant coliforms* as bacterial indicator of microbial drinking-water quality should be tested on all samples. The widespread-use and comparable rapidity of the tests for thermotolerant coliforms justifies their inclusion. Sections 5.2 and 5.3 outline current knowledge, strengths and weaknesses with regard to possible indicators of microbial quality.
- *Turbidity* should be tested on all samples (for justification, see Section 5.4 and Chapter 7).
- *pH* should be tested on all samples (for justification, see Section 5.4 and Chapter 7).

- *Chlorine residuals* should only be tested where the water is chlorinated. All samples (including household samples) taken from chlorinated supplies should be tested for free chlorine and total chlorine (for justification, see Section 5.4 and Chapter 7).
- *Sanitary inspections* should be performed for all water sources and household water sampled, using the formats provided (for justification, see Section 5.4, Chapter 6 and Annex 2).

**Table 5.1: Examples of pathogens transmitted through drinking-water (modified from WHO, 2011a)**

Pathogen	Health significance <sup>a)</sup>	Persistence in water supplies <sup>b)</sup>	Resistance to chlorine <sup>c)</sup>	Relative infectivity <sup>d)</sup>	Important animal reservoir
<b>Bacteria</b>					
<i>Campylobacter jejuni</i>	High	Moderate	Low	Moderate	Yes
Pathogenic <i>E. coli</i> <sup>e)</sup>	High	Moderate	Low	Low	Yes
Enterohaemorrhagic <i>E. coli</i>	High	Moderate	Low	High	Yes
<i>Salmonella typhi</i>	High	Moderate	Low	Low	No
Other salmonellae	High	May multiply	Low	Low	Yes
<i>Shigella</i> species	High	Short	Low	High	No
<i>Vibrio cholerae</i>	High	Short to long	Low	Low	No
<b>Viruses</b>					
Adenoviruses	Moderate	Long	Moderate	High	No
Enteroviruses	High	Long	Moderate	High	No
Hepatitis A virus	High	Long	Moderate	High	No
Hepatitis E virus	High	Long	Moderate	High	Potentially
Noroviruses	High	Long	Moderate	High	Potentially
Rotaviruses	High	Long	Moderate	High	No
<b>Protozoa</b>					
<i>Entamoeba histolytica</i>	High	Moderate	High	High	No
<i>Giardia intestinalis</i>	High	Moderate	High	High	Yes
<i>Cryptosporidium hominis/parvum</i>	High	Long	High	High	Yes
<b>Helminths</b>					
<i>Dracunculus medinensis</i>	High	Moderate	Moderate	High	No
<i>Schistosoma</i> species	High	Short	Moderate	High	Yes

a Health significance relates to the incidence and severity of disease, including association with outbreaks.

b Detection period for infective stage in water at 20 °C: short, up to one week; moderate, one week to one month; long, over one month.

c When the infective stage is freely suspended in water treated at conventional doses and contact times and pH between 7 and 8. Low means 99% inactivation at 20 °C generally in < 1 min, moderate 1–30 min and high > 30 min. It should be noted that organisms that survive and grow in biofilms will be protected from chlorination.

d From experiments with human volunteers, from epidemiological evidence and from experimental animal studies. High means infective doses can be 1–10<sup>2</sup> organisms or particles, moderate 10<sup>2</sup>-10<sup>4</sup> and low > 10<sup>4</sup>.

e Includes enteropathogenic, enterotoxigenic, enteroinvasive, diffusely adherent and enteroaggregative.

f *Vibrio cholerae* may persist for long periods in association with copepods and other aquatic organisms.

In addition to the parameters described above, a further water quality problem deriving from bacteria relates to toxic cyanobacteria. However, the actual health concern derives from toxins produced by these bacteria and released to the surrounding water. Cyanobacteria commonly appear in blooms in eutrophic source waters. An evaluation of their significance may be considered in higher level RADWQ.

## 5.2 *Indicator bacteria*

As a result of the issues raised in relation to pathogen monitoring and because most water-borne pathogens are derived from faeces, it is normal practice to use indicator organisms, usually bacteria, for the analysis of microbial quality of drinking-water. There are a number of indicator micro-organisms that may be used in drinking-water quality monitoring programmes.

### ***Escherichia coli* and thermotolerant coliforms**

The most commonly used bacterial indicator is *Escherichia coli* (*E. coli*) or, as a surrogate, thermotolerant coliforms. *E. coli* are derived almost exclusively from human and animal faeces and they also contain a few strains that are pathogenic (e.g. *E. coli* O157:H7). There is some evidence that *E. coli* are able to multiply in nutrient-rich tropical soils, although it is generally recognised that this phenomenon is limited: in most cases the indigenous bacteria would out-compete the *E. coli*.

Many programmes use thermotolerant coliforms as a surrogate for *E. coli*, because results can be obtained quickly and cheaply, although strictly speaking results from thermotolerant coliform counts only provide presumptive results for *E. coli*. The thermotolerant coliforms are a group of coliform bacteria that grow at 44°C and contain *E. coli* as well as other species that may have an environmental source. In temperate climates it is estimated that approximately 95% of thermotolerant coliforms are *E. coli*, but in tropical climates it is suggested that this proportion may be significant lower. This implies that some caution must be applied when interpreting the results of analysis, and highlights the need for other data collection methods as discussed further below. Thermotolerant coliform analysis can be performed using a variety of different techniques, and results can be obtained within 14-24 hours using relatively inexpensive methods.

### **Total coliforms**

The broader group of coliforms - often referred to as total coliforms - are also sometimes included in monitoring programmes. The total coliform group contains many different species of coliform bacteria, including both faecal and environmental species. Total coliforms include organisms that can survive and grow in soil and water environments. Therefore they are not useful as an indicator of faecal pathogens and of no sanitary or public health significance (WHO, 2011a). Total coliform analysis (with incubation at 37°C rather than 44°C) has often been used for chlorinated supplies, as they would usually be expected to be absent because of their sensitivity to chlorine. Their presence in water, therefore, is taken to imply that contamination has occurred. However, the significance of total coliform presence in such waters is likely to be limited as the majority will almost certainly derive from biofilm growing within the distribution system. The health significance of bacterial re-growth remains uncertain, but is believed to be negligible. Total coliform use is not recommended in any unchlorinated water supply as they would be expected to be present and have no sanitary significance. Therefore, total coliforms are not suggested for inclusion in basic/initial RADWQ.

### ***Faecal streptococci***

Faecal streptococci may also be used as indicators of faecal pollution. They generally survive longer in water environments than *E. coli* or the thermotolerant coliforms, are more resistant to drying and to chlorination (WHO, 2011a). Their use has been recommended, therefore, for groundwater receiving contaminated recharge water and in chlorinated distribution systems. However, they tend to be significantly less (by an order of magnitude) abundant in faeces than *E. coli*. A variety of techniques can be used for analysis and although some are simple, they are time-consuming because a result cannot be obtained for 48 hours. This may limit their usefulness in routine monitoring, but would have limited impact on their value in assessments. In RADWQ, their use may be considered in higher level assessments.

### ***Other microbial indicators***

Other indicator bacteria can be used, such as heterotrophic plate counts or *Clostridium perfringens*. These indicators all have specific characteristics that make their use valuable for certain applications (for instance in measuring treatment efficiency or as a surrogate for cyst presence). Indicators for virus presence are also available; for instance there are a number of bacteriophages (types of viruses that infect bacteria) that can be used. All these micro-organisms can be included in assessments where the resources permit. However, it is recommended that they only be considered in higher level RADWQ.

### **5.3 Critique of the indicator-based approach**

The principal current indicators used do have serious limitations. The physico-chemical parameters either directly influence microbiological quality (in the case of chlorine) or may influence disinfection efficiency and microbial survival (in the case of pH and turbidity). Together with indicator bacteria they form the basis for the minimum approach to water quality monitoring. The weaknesses of current indicators in predicting health risks has been noted as there is evidence of infection by waterborne pathogens when indicators are not present in water.

The suite of traditional faecal indicators (such as *E. coli*, thermotolerant coliforms, faecal streptococci) provides a useful tool in signalling faecal pollution of water and thus in preventing water-borne disease. However, these bacterial indicators provide far less reliable information on the possible occurrence of viral and protozoan pathogens. The presence of such pathogens in the absence of bacterial indicators is mainly due to the different nature of the pathogen and the indicator. The most important reasons for the lack of correlation between *E. coli* or thermotolerant coliforms, respectively, and viral and protozoan pathogens are differential resistance to environmental conditions and differential sensitivity to disinfection. It has therefore been suggested that the current indicator bacteria are not adequate alone to predict pathogen presence.

On the other hand, there are strong arguments that can be made for continued use of indicator bacteria as the principal method for monitoring the microbial quality and thus, indirectly, the likelihood of pathogen presence in drinking-water supplies. The use of the standard indicators has done much to improve health, and their abandonment due to recognised weaknesses is unjustified and likely to be counter-productive to health.

The limitations of the current bacterial indicators are related to both inherent weakness and misuse in the application and interpretation of the results of analysis rather than the imperfections of the system itself. The original development of standards for water quality, based on indicator bacteria in the early 20<sup>th</sup> century, was designed to verify treatment system performance. This was a logical extension of the process of public health-based water quality control linked to the development of treatment processes (in particular slow sand filtration and disinfection) which proved to be effective in pathogen removal.

The interpretation of the results of indicator bacteria analysis in the context of standards illustrates the importance of understanding the meaning of the absence, presence and numbers of faecal indicator bacteria. Some people equate an absence of faecal indicator bacteria with an absence of pathogens. This may not be true given the evidence of water-borne infections resulting from drinking-water meeting current standards, and this was not the original intention of such indicators. Furthermore, others may equate the presence of faecal indicator bacteria with confirmation of the presence of pathogens. However, in reality it merely implies that the risk of pathogen presence has increased, as there is evidence of recent faecal contamination.

Analysis of microbial quality contains some degree of potential for false positive and false negative results in relation to pathogen presence. This is of relevance in that the current application of the faecal indicator bacteria means that action is usually only required when indicator bacteria are detected. In terms of direct public health consequences, the false negative result (i.e. when pathogens are present, but faecal indicator organisms are absent) is of greatest concern. In developing countries, however, the false positive result (i.e. when faecal indicator organisms are present, but pathogens are absent) may be of equal concern in that it would imply that some form of action (and therefore investment) is required to mitigate a public health risk that does not actually exist. This may lead to a focus on improving water quality in situations where greater attention to other aspects of water supply improvement, hygiene behaviour or sanitation, would yield greater health gains. Furthermore, the meaning of true positives/negatives (i.e. when both faecal indicator organisms and pathogens are both present/absent) should also be carefully considered in the context of multiple routes of infectious disease transmission. In most cases a degree of contamination of drinking-water can be tolerated with limited increased health burdens if this means that resources can be allocated to other improvements in water and environmental sanitation.

In this context, the relative numbers of faecal indicators in a water supply are more important than simple presence, as increasing numbers of indicator bacteria imply recent faecal contamination has occurred and so, as a consequence, the risk of pathogen presence has increased. Whilst this would be most effective for pathogens of similar type (i.e. bacteria) it may still provide some indication of the likelihood of other pathogens being present.

In conclusion, use of indicator bacteria remains an important element in protecting public health, particularly in lower-income countries. Indicator bacteria retain an intrinsic value in predicting contamination and indirectly the public health risk posed by a specific water supply. The monitoring of indicator bacteria remains an effective tool for the evaluation of risks of major outbreaks derived from drinking-water. However, it is clear that sole reliance on faecal indicator bacteria is unwise. Therefore, there is a need to use a suite of indicators that can be used to describe overall risks of pathogen presence.

#### ***5.4 Other parameters of significance to microbial quality***

Turbidity, pH and chlorine residuals, where supplies are chlorinated, are widely accepted as important water quality parameters supporting the analysis and interpretation of microbial drinking-water quality. This set of parameters constitutes, with indicator bacteria testing, the 'critical basis for a minimum approach to water quality monitoring as they either directly influence microbial quality (in the case of chlorine) or may influence disinfection efficiency and microbial survival (in the case of pH and turbidity). Very low chlorine residuals or high turbidity, even in the absence of faecal indicator bacteria, may give cause for concern as they imply reduced protection against contamination and in the case of turbidity may indicate that sanitary integrity and hence water safety has been compromised. Brief details for pH and turbidity are included in Chapter 7 with other physical/aesthetic parameters.

In addition to these parameters, a sanitary inspection should always be undertaken at the time when the water sample is collected. Sanitary inspections are visual assessments of the infrastructure and environment surrounding a water supply. They assess risks to water safety by taking into account the condition, devices, and practices in the water supply system that pose an actual or potential danger to the health and well-being of the consumers. The most effective way to undertake sanitary inspections is to use a semi-quantitative standardised approach using logical questions and a simple scoring system as described further below in Chapter 6 and Annex 2. Sanitary inspections are complementary to water quality analysis, and there is an increase in the power of subsequent analysis when both types of data are available. Sanitary inspection has an additional value as it

provides a longer-term perspective on risks of future microbial and anthropogenic (but not naturally occurring) chemical contamination of water supplies.

### **5.5 Analytical methods**

The choice of analytical methods is an important aspect of establishing the assessment protocols, standard operating procedures and quality control. Analysis for thermotolerant coliforms can involve presence/absence testing or enumeration.

Presence/absence tests are generally only appropriate in circumstances where thermotolerant coliforms are rarely found and when contamination occurs only at low levels. As it is often more useful to know about the degree of contamination when setting priorities, the use of presence/absence tests will inhibit the development of a full understanding of the scale and range of microbial quality of water. In particular, such tests reduce the ability of the assessment to compare the quality of different sources of water and between sources of water and water stored in the home. The value of quantifying the level of contamination is that it will allow countries to make better-informed policy and management decisions regarding future water and sanitation investment. Therefore, for RADWQ, presence/absence tests are not recommended because of the limited information the results of such tests provide.

Two approaches to thermotolerant coliform testing are available where enumeration is required: the multiple tube method and membrane filtration. In the former, the analysis of several tubes containing different amounts of a sample allows a statistical estimate of the numbers of bacteria in the water and is sometimes referred to as the most probable number (MPN) approach. This technique is more cumbersome, requires greater training in the interpretation of results and often leads to delays in obtaining results. However, it is effective when samples are turbid and where the organisms are injured. Research is currently undertaken on the development of low-cost field kits based on the MPN method.

Membrane filtration is a more recent technique, but one which has been an accepted standard method for many years. The advantage of the membrane filtration technique is that direct counts of bacteria may be made from colonies grown on filter papers incubated on nutrient media for 14-24 hours. However, although direct counts are made, it should be borne in mind that microbe densities will vary within the sample and therefore the value obtained is still subject to statistical confidence limits. The membrane filtration technique is not appropriate where samples are turbid as the filter may block and the suspended sediment may interfere with bacterial growth. However, the membrane filtration technique is simpler and quicker to perform than MPN and the results are often easier to interpret. Consequently this technique is recommended for RADWQ.

### **5.6 Field and laboratory-based approaches**

The analysis of water samples can be carried out in laboratories or through the use of field equipment. Laboratory approaches have some advantages in terms of the numbers of samples that may be processed in one day and some advantages in securing an analytical environment. However, laboratory-based approaches have many drawbacks, particularly when sampling is done of remote rural supplies. These particularly relate to sample deterioration, which is often significant, and increased transportation costs, especially in countries where the percentage of rural population is high.

A number of proven simple, low-cost field techniques are available for microbial analysis. There appears to be no significant difference in the reliability of results obtained from such kits in comparison to laboratory testing providing the staff using them are properly trained and maintain an



aseptic technique. However, as discussed in Section 4.4, analytical quality control in water quality analysis is important and should be properly addressed during assessments.

Field test kits have an advantage over the use of laboratories because problems with sample deterioration during transport and transport costs can be reduced. Use of field equipment also increases the potential for community involvement in the process of surveillance and the portability of field equipment means that it can be readily deployed as a health education tool in its own right.

The principal perceived disadvantages of field equipment relate to numbers of samples that can be processed. The limitations of number of samples that can be processed in one day may lead to greater numbers of staff or more frequent visits to the field in order to collect and analyse the numbers of samples required. Given the distances involved in sampling water supplies in many rural areas, however, this rarely inhibits data collection significantly. In urban areas it may be an advantage as more frequent analysis provides better information. It is therefore recommended that in the basic/initial RADWQ, field testing kits be used for all microbial analysis. In urban areas, analysis could also be carried out in central laboratories. However, for consistency it is essential to confirm that methods used in the laboratory give the same results as the field methods.

#### ***Available kits***

There are a number of suitable kits available for microbial analysis. The most commonly used kits use membrane filtration and have built-in incubators; they can come with either a single or double incubator pot. All kits are able to run from either mains electricity or built-in batteries, although the life of these varies significantly. They can also use solar panels for charging the batteries. All kits use methanol for sterilisation, but this cannot be transported by air freight and will need to be purchased in-country. In addition, most kits are usually supplied with a range of additional equipment and a limited set of consumables as standard (often sufficient to conduct approximately 200 tests) to test for turbidity, pH, chlorine residuals and other chemical parameters. Additional consumables must then be purchased.

There may be locally-available/manufactured kits for microbial analysis using the membrane filtration technique that are equally acceptable and may have added advantages such as availability of consumables and in-country expertise in their use.



## 6 SANITARY INSPECTIONS

Water quality analysis provides detail on quality at the time of sampling but is limited in its ability to provide information on either the causes of pollution or likely future trends. In contrast, although perceptions of water quality may be unreliable, observation is a very useful tool for identifying possible hygiene risks that could affect the current and future quality of water supplies. Two useful observational techniques are sanitary inspection (or sanitary surveys) and qualitative visual inspection. Both techniques require inspectors to identify potential risks to the quality of the water (i.e. at the source, point of abstraction, treatment works, service reservoirs, in the distribution system or in households). Identification of potential risks provides information not only on possible causes of both past and future pollution but also on actions necessary to manage future water quality.

### 6.1 *Sanitary inspection techniques and forms*

Sanitary inspection is a key approach that has been promoted consistently by WHO through the Guidelines for Drinking-Water Quality (WHO 1997; 2011a) and by other water quality regulatory bodies such as the United States Environmental Protection Agency (USEPA, 1999). Observation is used to identify, assess and record the likely hazards, risks and possible pollution problems that may threaten drinking-water quality at the source, point of abstraction, treatment works, service reservoirs or distribution system in both rural and urban areas. Whilst these sanitary inspection techniques are used principally to evaluate the likelihood of faecal contamination of water and, therefore, of microbial quality, they can also provide an assessment of other threats to water quality. They may be components in the development and implementation of water safety plans (WSP), notably for community management and control of water sources.

Most sanitary inspection activities consider a variety of factors, which can be grouped into three broad categories:

- *Hazard factors* as potential sources of faecal materials that may become a risk to the water supply (for example, a pit latrine that is too close to a hand-dug well).
- *Pathway factors* as potential routes by which contamination may enter into the water supply (for example, a broken access cover for a spring-box, or leaks in water supply pipes).
- *Indirect factors* are these which would facilitate the development of pathways (for example, inadequate fencing around a protected spring, which may allow animals to have access to the areas behind the spring box where they will erode the cover and may deposit faeces).

In many cases the presence of factors from each category is required in order to form a risk to water supply and for contamination to result.

Sanitary inspection techniques are generally used in three closely linked ways:

- identification of specific causes of known contamination;
- identification and evaluation of factors likely to affect the long-term risk of contamination; and
- assisting with monitoring and evaluation of operation and maintenance activities for water supplies.

Sanitary inspections should be undertaken in basic/initial assessments at the following locations:

- at the source and intake to assess whether the quality of the raw water is at risk, and whether the abstraction method is satisfactory;

- at the treatment works to assess whether suitable treatment processes are being used, and whether correct procedures are being followed;
- in the distribution system, including within households with direct connections, and at service reservoirs, to assess whether the quality of the water is at risk during distribution;
- at all point sources (i.e. boreholes/tubewells, protected springs, dug wells); and
- household water containers.

Sanitary inspection usually makes use of a report form containing a check-list of questions, which can be answered using a mixture of visual observation and user interview. Each question is usually phrased in such a way that a 'Yes' answer indicates a potential risk that could threaten the quality of water. A 'No' answer indicates that there is no risk, or a negligible risk. Use of questions provides a simple, rapid, and accurate means of assessing the risks threatening a particular water source or installation. An overall sanitary inspection risk score (the number of questions answered 'Yes', optionally given as a percentage) can provide an indication of the likely risk to microbial quality of the water.

Report forms can be prepared or adapted for specific water sources and situations, although standard lists of questions should be used to ensure comparability and to minimise the possible subjective nature of data collected. Pictorial versions of sanitary inspection forms can be developed for use by communities where levels of literacy may make use of written versions inappropriate. In this format, the person or group performing the sanitary inspection uses visual observation to put a cross in a box next to the numbered component in the picture that represents the risk. One option is for the assessor to also shade a box in a table on the picture for each observed risk: the table can be colour coded so that the degree of risk is easily shown. Examples of a pictorial sanitary inspection form corresponding to a written form, for a protected spring are given in Figure 6.1 and Box 6.1, respectively.

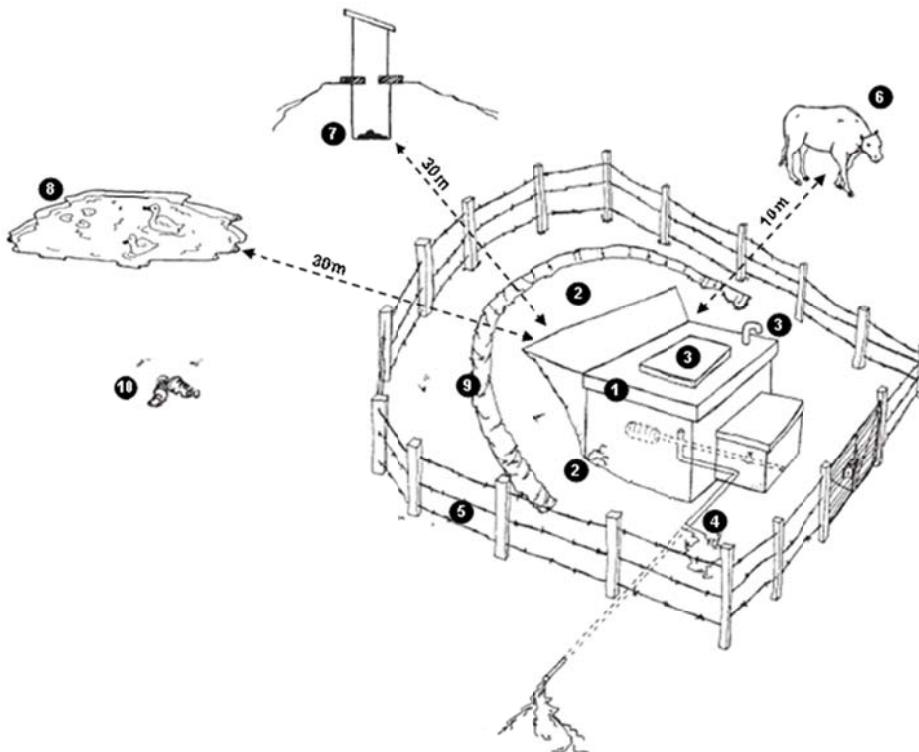

**Figure 6.1: Example of pictorial sanitary inspection form for a protected spring (adapted from WHO, 1997)**

**Box 6.1: Example of sanitary inspection form for a protected spring**

**I General information:**

- a. WSS No.: .....
- b. Village/Town: .....
- c. Date of visit: .....
- d. Broad area/region: .....
- e. People served: .....

**II Specific diagnostic information for assessment:**

*(Please indicate at which sites the risk was identified)*

**Risk**

- 1. Is the collection or spring box absent or faulty? Y/N
- 2. Is the masonry or backfill area protecting the spring faulty or eroded? Y/N
- 3. If there is a spring box, is there an unsanitary inspection cover or air vent? Y/N
- 4. Does spilt water flood the collection area (e.g. from overflow pipe)? Y/N
- 5. Is the fence absent or faulty? Y/N
- 6. Can animals have access within 10 m of the spring? Y/N
- 7. Is there a latrine uphill and/or within 30 m of the spring? Y/N
- 8. Does surface water collect uphill of the spring within 30 m? Y/N
- 9. Is the diversion ditch above the spring absent or non-functional? Y/N
- 10. Are there any other sources of pollution uphill of the spring (e.g. faeces, solid waste)? Y/N

**Total score of risks: ...../10**

**III Results and comments:**

- a. Sanitary inspection risk score (SIRS) (tick appropriate box):

9-10 = Very high	6-8 = High	3-5 = Medium	0-2 = Low
------------------	------------	--------------	-----------

- b. The following important points of risk were noted:
  - List nos. 1-10
  - Additional comments (continue on back of form if necessary)
- c. *Indicate if the spring is not protected!*

**IV Name and signature of assessors:**

Using the example of a sanitary inspection form for a protected spring as given in Box 6.1, question 1 ‘*Is the collection/spring box absent or faulty?*’ is asked as the spring box helps to protect the water from contamination by surface run-off. Therefore, if the spring box is absent or faulty there is pathway for pollution to enter the source, posing a risk to water quality. Were it absent or faulty the assessor would circle the ‘Yes’ answer. Using the pictorial form the assessor would mark next to number 1 on the figure and shade in one of the boxes.

A set of recommended sanitary inspections forms for a number of water supply types and household water, developed for JMP-linked rapid assessments, together with explanatory notes for the questions, is included in Annex 2. Before using the sanitary inspection forms they should always be reviewed to see if any changes are necessary to reflect local conditions (see Box 6.2). Training in the development of sanitary inspection forms and in their application in the field is essential to ensure that assessors understand the purpose of the questions and, therefore, are able to judge whether a ‘Yes’ or ‘No’ answer is correct.

For simplicity, all risks are assigned equal weight for JMP-linked rapid assessments, although the importance of different risks will be likely to be site-specific, and contamination may not be directly proportional to the number of risks identified. Each fault increases the likelihood that contamination

has occurred or could occur, and the total number of risks represents the likely overall risk of contamination. Remedial actions to eliminate one or more of the identified risks may therefore lead to some reduction in contamination. More detailed subsequent analysis may be required to investigate the potential impact of specific risk factors on water quality.

**Box 6.2: Example of the value of training from the RADWQ pilot**

One query raised during the RADWQ pilot related to the inclusion of questions relating to the presence/absence of fencing at water points. This question relates to animal access which may not only cause damage to structures and consequent risk to water quality but also increase risk of pollution by animal excreta. However, in some communities a fence was seen as culturally unacceptable as it would indicate private ownership of the water point and discourage access by poorer members of the community. As there would, in these areas, be no fencing the assessors thought that inclusion of the question would give a false impression of the risk to water quality. However, animal access to water points was a risk factor so, following discussions with the assessors, the question was retained. Reference to the reason for the absence of fences and its impact on sanitary inspection data was included in the discussion of results.

Sanitary inspections usually concentrate on the immediate area around a water source, and more distant risks affecting water quality may not be identifiable. The use of sanitary inspection forms is appropriate for water sources, but surveys of more extensive facilities, such as piped water distribution systems or water treatment works, may be more difficult. In these situations, use of interviews is appropriate to supplement a list of sanitary inspection questions. Interview questions that concentrate on issues which will be known to operators or users can provide a good broad indication of both likely risks to quality and of operation and maintenance performance.

In piped water supplies where inspection of the entire network and all service reservoirs may not be possible or realistic, causes of contamination may occur far from the point of sampling. Localised problems are, nevertheless, often the cause of contamination in piped networks. For piped water supplies, broader issues (such as whether supplies are intermittent or whether there are obvious leaks) can be included in a sanitary inspection or a user interview component. Furthermore, the use of standardised formats can provide a good indication of the domain of contamination - that is whether it relates to major supply faults or is due primarily to problems very close to the sampling point. This therefore provides the inspector with a good initial indication of where further investigation is needed. Such approaches may also be supported by other techniques such as mapping chlorine residuals and looking for broad trends in residual values (e.g. by area or sampling date).

In water treatment works, it would be preferred for a detailed audit to be undertaken of the plant covering individual process performance. Whilst this may be included in higher level assessments, it is excluded from basic/initial assessments where brief interviews and completion of the sanitary inspection form in Annex 2 would be sufficient. However, as knowledge of water treatment technologies may be limited for water quality analysts, more detailed explanations for sanitary inspection questions are provided in Annex 2 to assist with the completion of the forms.

In some aquifer types (particularly fracture aquifers, in which water is present in fractured rocks) sources of groundwater contamination may be present beyond the immediate area of the sanitary inspection. Without a full hydrogeological risk assessment it may be difficult to identify these risks. By carrying out a sanitary inspection, however, a good indication can be obtained of whether this may be the case. If groundwater is found to be contaminated, but the inspection reveals no identifiable risks, then it may be assumed that contamination is occurring remotely from the source.

Further guidance and advice on the design of sanitary inspection forms and the practical implementation of sanitary inspections is provided by WHO (1997), USEPA (1999) and Howard (2002a; 2002b), for example.

## **6.2 *Pollution risk appraisal***

Sanitary inspection techniques have primarily been developed to address problems of microbial contamination and may not be as effective for chemical contaminants. However, risk assessments can also provide useful insights in relation to chemical risks in water supply and can help in directing further investigations and interventions to improve water quality.

A simple format for assessing environmental risks is given in Annex 2. This form could be used in the inspection of water sources supplying piped water systems and water treatment works. It can be filled out by interviewing the operator of the works and provides qualitative data on major source water problems. This form is adequate for basic/initial assessments but should be expanded for higher level assessments, eventually leading to comprehensive environmental audits and detailed hydrogeological risk assessment.

## **6.3 *Visual inspection***

Visual inspection is similar to sanitary inspection, but is less structured. It provides qualitative data that are collected by observation, and then reported in spoken or written form. The technique requires those who undertake inspections to have a basic knowledge and understanding of public health principles, and to be thorough and professional by nature.

For example, visual inspection is a technique that may be used to assess domestic hygiene practices and the risks affecting the quality of water within the home. Visual inspection entails observing how water is stored, handled and used within individual homes, so that unhygienic practices can be identified. Standard reporting forms may be produced. The use of standard forms encourages objective assessment, so that data obtained by different inspectors or in different areas can be compared directly.

However, for basic/initial rapid assessments, it is recommended to include a sanitary inspection form for household water (as shown in Annex 2) rather than use visual inspections; a more detailed questionnaire may be used in higher level assessments.

## **6.4 *Advantages, limitations and applications of techniques***

Inspection techniques and analytical approaches are complementary activities and neither fully replaces the other. Analytical techniques can provide data about the quality of water samples, but cannot provide reasons for the values obtained. In contrast, observational techniques can identify possible risks or pollution problems, but cannot provide evidence of whether pollution is occurring. It is therefore important that observational and analytical techniques are used in conjunction with each other. Possible roles for water quality analyses, sanitary surveys and visual inspections are summarised in Table 6.1 below.

Sanitary inspection relies on observation. Thus, it needs no special equipment, and it is quick and cheap. Some training may be required, but it does not require highly-trained staff. Observational techniques are location-specific and the forms and approaches used should be developed to take into account local conditions. Although an element of judgement is needed by the person undertaking the inspection, if standardised formats are used and appropriate training provided, there is usually a very significant concordance between different inspectors when independently inspecting specific facilities.

**Table 6.1: A comparison of analytical and observation techniques for assessing water quality**

<b>Water quality analysis</b>	<b>Sanitary inspection</b>
Water quality analysis is expensive, requires equipment and competent, skilled staff, and therefore is not always easy to perform regularly or routinely.	Sanitary inspection is cheap, requires no equipment or highly-skilled staff, and may easily be performed regularly or routinely.
Water quality analysis gives only a snapshot - a record of the water quality at the time of sampling.	Sanitary inspection can reveal conditions or practices that may cause isolated pollution incidents or longer-term pollution.
Water quality analysis will indicate whether a water is contaminated; but will not, usually, identify the source of contamination.	Sanitary inspection reveals the most obvious possible sources of contamination, but may not reveal all sources of contamination (e.g. remote contamination of groundwater). Sanitary inspection does not provide confirmation of whether contamination has occurred.
Water quality analysis can provide data about the physical, chemical and microbial quality of water samples.	Sanitary inspection usually identifies risks that may affect the microbial and physical quality of water. Risks to the chemical quality of water are not usually identified.

Sanitary inspection has been shown to be an effective tool for water quality surveillance programmes. Sanitary inspection identifies possible pollution problems that may threaten drinking-water quality, and these potential problems are often associated with specific practices and the physical condition of facilities. Questions answered with a ‘Yes’ on the reporting form identify specific risks, and remedial action can often be identified and implemented to minimise the risks. In some cases action may be necessary to repair facilities; in others, hygiene education may be necessary to change the hygiene practices of individuals or communities. In certain cases, circumstances outside their control may make it impossible for a community or support agency to minimise risks.

An advantage of sanitary inspection is that findings can be discussed at the time of inspection with users and community members. This will greatly facilitate their understanding of identified risks and thus their willingness to take remedial actions. On the occasion of the visits, inspectors may provide on-site advice to community members in response to shortcomings identified. This learning approach should explicitly be built-in into the RADWQ implementation strategy, if possible.

### **6.5 Risk-priority matrix**

The WHO Guidelines for Drinking-Water Quality (WHO, 2011a) highlight the importance of using data to assess the relative priority for action for water supplies and/or technologies by combining analysis of sanitary inspection and water quality data. The classification combines information providing a longer-term perspective on risks of future microbial contamination (obtained from the sanitary inspections) with “snapshot-nature” information (current contamination with thermotolerant coliforms from water quality analyses). The ranking of supplies in such a way is a powerful tool that supports priority setting for individual interventions, improving water safety and thus effective and rational decision making.

This matrix approach was adapted for use in RADWQ basic/initial level assessments giving a risk-priority matrix that could be used when interpreting data and to provide a tool to aid politicians and water supply managers in planning/targeting future activities and budget allocations. The example matrix, presented in Table 6.2, has areas that are categorised as low, intermediate, high or very high risk based on the combination of thermotolerant coliform counts and sanitary risk scores. Based on these categories, priority action levels can be assigned. A practical example can be found in Table 8.7.



**Table 6.2: Example risk-priority matrix (WHO, 2011a)**

Thermotolerant coliform count (TTC/100ml)	Sanitary inspection risk score (susceptibility of supply to contamination from human and animal faeces)			
	0-2	3-5	6-8	9-10
<1				
1-10				
11-100				
>100				

**Legend:**

Risk level	<b>Low risk</b>	<b>Intermediate risk</b>	<b>High risk</b>	<b>Very high risk</b>
Priority action level	No action required	Low action priority	Higher action priority	Urgent action required

### **6.6 Recommendation for RADWQ**

For all rapid assessments sanitary inspections should be performed for all types of point sources of water, piped water supplies and household water. A standard set of sanitary inspection forms is provided in Annex 2, which can be adapted to the local conditions using informed expert judgement. The data from these inspections should be combined with data on bacterial quality to produce risk-priority matrices. Pollution appraisal, gradually leading to complete environmental appraisal, should be included in higher levels of assessments as technical, financial, human or institutional resources become available and the range of indicators/parameters assessed is expanded.



## 7 CHEMICAL AND PHYSICAL QUALITY MONITORING

There are numerous chemical substances that can be found in water and that may be of concern for public health, acceptability of water and operational performance. The WHO Guidelines for Drinking-Water Quality sets health-based guideline values for over a hundred substances (WHO, 2011a). It is expensive, difficult and largely unnecessary to test for all these parameters even within an assessment exercise, and therefore priorities have to be set on their selection (see for instance Thompson *et al.*, 2007). In addition to chemical substances, there are a set of physical characteristics of water that should also be included in assessments of water quality as they are useful indicators of change in quality and are often cited by consumers as reasons for rejecting a water from a specific supply.

Chemical and physical characteristics may have natural and anthropogenic sources. All natural water contains a range of inorganic and organic chemicals. Inorganic chemicals derive from the rocks and soil through which water percolates or over which it flows. Organic chemicals derive from the breakdown of plant material or from algae and other microorganisms that grow in the water or on sediments (WHO, 2011a). Chemical and physical parameters may show both temporal and spatial variation in their occurrence and concentration, with temporal (e.g. diurnal or seasonal) variation being greater in surface waters and shallow groundwater than deep groundwater. The microbial quality of shallow groundwater and surface waters is usually the principal issue of concern for these sources. The chemical quality of shallow groundwater and surface water tends to be primarily related to human activity (e.g. nitrate) so that, whilst chemical quality may be poor, prevention measures are usually possible and contamination may be relatively short-lived in surface waters given rapid through-flow.

In deeper groundwaters, microbial quality is often excellent and therefore chemical quality is of a higher priority. Furthermore, chemical contaminants are more likely to be natural, and therefore removal rather than prevention may be required. Slow through-flow may lead to long-term anthropogenic contamination problems. The quality of deep groundwater is generally stable, however, so the required frequency of monitoring is lower than that for shallow groundwater and surface water.

Although pH, turbidity and chlorine residuals are all physical or chemical parameters, and are described and discussed in this chapter, they are also included in the chapter on microbial quality (see Section 5.4). This is because, although all may have an impact on the acceptability of water, their primary effect is in relation to microbial quality, and in particular in relation to disinfection processes.

### 7.1 *Impact of chemical contamination*

Some chemicals constitute a health hazard because of their toxicity (e.g. nitrate, fluoride, and arsenic). Others may lead to indirect adverse health impacts (e.g. salinity, hardness) because they render the water objectionable and may result in consumers rejecting the water in favour of an alternative, possibly palatable but microbially contaminated, source of water. Naturally-occurring chemicals in water are commonly chronically rather than acutely dangerous to health, with exposure to (low) concentrations over several years being required for long-term impacts on health. Chronic health impacts have particularly been recognised internationally through the concerns over the health effects from bio-accumulation of arsenic and fluoride (see Section 7.4). Acute health impacts due to naturally-occurring chemicals also occur, such as diarrhoea induced by high sulphate levels (for those not accustomed to these levels), but such effects tend to be rare.

Chemicals derived from human activity are also of concern for health. Of these, the serious health risk posed to infants (particularly under six months of age) by high nitrate concentrations is the most important. Other anthropogenic pollutants (e.g. heavy metals) may also cause health problems although, like the naturally-occurring chemicals, these tend to have chronic impacts unless a specific poisoning event occurs, after accidental spills, for example.

In addition to their health and aesthetic impact, the physical and chemical quality of water may also affect the selection and efficiency of treatment processes. There can be marked cost impacts of changes in parameters such as pH, turbidity, colour or iron through increased coagulant and/or chlorine demand. In communities unable to meet these additional (possibly seasonal) demands there may be a sudden decrease in the quality of distributed water, with a potential for serious effects on health.

## **7.2 *Parameter selection for rapid assessments***

As discussed in Chapter 2, the selection of chemical parameters for monitoring and assessment programmes should reflect their occurrence in the country or area of investigation and water source types, potential health impact, analytical capacity and the ability to remove the substance through treatment or source protection measures. The cost of analysis for some parameters is relatively high, notably those present at low levels but known to bio-accumulate (such as organics and heavy metals). Priority should be given to those chemicals that will lead to rejection of water supplies, or that have known toxic effects and which are persistent in water.

When a water source is being developed, a pollution risk assessment should be undertaken with a full suite of chemical analyses being performed for parameters identified. These data should be used to evaluate whether the source could be used and whether additional treatment is required. The role of regular and systematic pollution risk assessments in drinking-water catchments is important in determining whether additional chemical parameters need to be included in assessment and monitoring programmes. Changes in land-use, new industrial developments and urban growth within the catchment should be carefully evaluated in the light of potential pollutants that may be used or produced and possibly released into the environment.

The chemical parameters of concern in distributed water relate to chemicals present in the source water and to those used in the treatment process. The aim of the assessment may be to assess the potability of the treated water, the efficiency of the treatment process, the integrity of the distribution system and/or household management of water. In general, most other chemicals need not be monitored in distribution systems, although turbidity, colour and conductivity should be tested in distribution as should iron (because of corrosion of galvanised iron pipes) and lead and/or copper (where lead or copper pipes are known to have been used in plumbing).

In line with the resource constraints of a rapid assessment (e.g. time, finances, personnel), a core set of chemical and physical parameters is recommended for basic/initial RADWQ assessments. As discussed in Chapters 2 and 5, parameter selection is based on those related to microbial quality (e.g. pH, turbidity and chlorine residuals) and those with health-based WHO guideline values (WHO, 2011a) that have a widespread occurrence, can be determined easily, quickly and cheaply, and/or are of global public health concern. In addition, appearance and conductivity, both aesthetic parameters, which can cause rejection of water, are also included. These core parameters are detailed in Table 7.1 together with justifications for their inclusion and selected methods of field analysis. These are recommended for inclusion in any rapid assessment of water quality. However, some of these core parameters may be omitted if there are adequate data to show that they are absent in a given country or region. In the absence of data, however, they should be included in the assessment. Examples of additional optional parameters are presented in Table 7.1; they may be

included if known to be present at levels causing health concerns in a country or region under investigation. Omissions and additions of core or optional parameters may be area-specific rather than nationwide.

Brief details on the core and some of the optional physical and chemical parameters are provided in Sections 7.3 and 7.4, with a brief explanation of why they are considered important. These details are not fully comprehensive but aim to provide a first overview. For additional information reference is made to the WHO Guidelines for Drinking-Water Quality (WHO, 2011a) and Thompson *et al.* (2007).

**Table 7.1: Summary of core and optional parameters for basic/initial RADWQ**

Parameter	Suggested value	Primary reason for designation	Possible sources	Field methods recommended for basic/initial assessments
<b>Core physical parameters</b>				
Colour or appearance	15 TCU <sup>a</sup> or acceptable	Consumer acceptability Technical: impact on cost or ease of treatment Changes with time indicate changed quality that may need further investigation.	Organic matter, metals, industrial pollution	For basic/initial rapid assessments, appearance should be used as a surrogate for colour using a five-point scale (clear; clear but coloured; slightly cloudy; cloudy; dirty/opaque)
Odour	Not objectionable	Consumer acceptability Technical: impact on cost/ease of treatment Changes with time indicate changed quality that may need further investigation.	Organic matter (especially algae), metals, industrial pollution	Olfactory – subjective, wide-ranging classification (e.g. rotting vegetation, chemical, fishy, oily)
Conductivity	1,400 $\mu\text{S}/\text{cm}^{\text{b}}$	Consumer acceptability Changes with time indicate changed quality that may need further investigation.	Dissolved solids	Pocket meter with temperature compensation (0-20 mS/cm)
pH	6.5-8.5 <sup>a</sup> < 8.0 <sup>c</sup>	Technical: impact on effective treatment, particularly chlorination, and corrosivity in distribution	Organic matter, acids or alkalis	Pocket pH meter (1-15 pH) Comparator (1-15 pH) Photometer (1-15 pH)
Turbidity	5 NTU <sup>a</sup> < 1 NTU <sup>c</sup>	Consumer acceptability Technical: impact on effective removal of microorganisms and disinfection Changes with time indicate changed quality that may need further investigation	Suspended or colloidal matter (inorganic or organic particles)	Turbidity tube (5-500 NTU) Turbidity meter (0-1000 NTU)

Parameter	Suggested value	Primary reason for designation	Possible sources	Field methods recommended for basic/initial assessments
<b>Core chemical parameters</b>				
Arsenic	0.01 mg/l <sup>e</sup>	Health	Naturally occurring, industrial pollution	Visual colour detection kits (for qualitative analysis) (10-500 µg/l) Gutzeit colorimetric method (for quantitative analysis) (2-1000 µg/l)
Fluoride	1.5 mg/l <sup>d</sup>	Health	Naturally occurring, industrial pollution	Photometer (0 - 5 mg/l) Comparator (0 -3.5 mg/l)
Nitrate	50 mg/l <sup>d</sup> (as NO <sub>3</sub> )	Health: particularly for infants aged <6 months	Animal and human waste, inorganic fertilisers, decaying vegetation	Photometer (0-20 mg/l as nitrogen); comparator (0 -15 mg/l as nitrogen)
Iron <sup>f</sup>	0.3 mg/l <sup>a</sup>	Consumer acceptability Technical: accumulation of deposits in the distribution system	Naturally occurring, plumbing, industrial pollution	Photometer (0-10 mg/l) Comparator (0.1-10 mg/l)
Chlorine residuals	≥ 0,2 mg/L <sup>b</sup>	Health: protects microbial quality in distribution and storage	Disinfection with chlorine	Photometer (0-5mg/l)
<b>Optional parameters</b>				
Aluminium	0.2 mg/l <sup>a</sup>	Consumer acceptability	Water treatment, industrial pollution	Photometer (0 – 0.5 mg/l) Comparator (0 –0.5 mg/l)
Ammonia	1.5 mg/l <sup>a</sup>	Consumer acceptability Technical: impact on cost/ease of treatment	Metabolic, agricultural, and industrial processes, disinfection with chloramine	Photometer (0-1.0 mg/l as nitrogen)
Copper	2.0 mg/l <sup>d</sup>	Health	Household plumbing and solder, industrial pollution	Photometer (0 – 5 mg/l)
Lead	0.01 mg/l <sup>e</sup>	Health	Household plumbing and solder, industrial pollution	No simple field-based method with range and accuracy necessary Atomic absorption spectrophotometry (laboratory-based)
Manganese <sup>f</sup>	0.1 mg/l <sup>a</sup>	Consumer acceptability Technical: accumulation of deposits in the distribution system	Naturally occurring	Photometer (0 -0.03 mg/l) Comparator (0 –0.03 mg/l)

a No health based WHO GV but suggested for aesthetic and/or technical reasons.

b No health-based WHO GV but suggested for aesthetic reasons. Value is equivalent to approximately 1,000 mg/l total dissolved solvents.

c No health-based WHO GV but suggested for effective disinfection with chlorine.

d Health-based WHO GV.

e Provisional health-based WHO GV.

f Iron and manganese have similar sources and cause similar problems. Iron is recommended for aesthetic and/or technical reasons but manganese may be included as an additional parameter or as an alternative to iron.

The chemicals included in more detailed or higher level assessments, should be determined in-country based on a systematic review of known and likely water quality problems. Testing is

particularly justified if there is either a known and on-going pollution concern, specific land-use patterns associated with the release of pollutants or evidence of past pollution events. This parameter selection process may be done using existing data and national decision-making tools, supported by guidance provided by the WHO on the selection of chemicals for inclusion in monitoring programmes and assessing priorities for risk management (Thompson *et al.*, 2007).

### **7.3 Physical parameters**

The physical parameters included as core parameters suggested for basic/initial rapid assessments are detailed in Table 7.1. Note that pH and turbidity, although physical parameters, are essentially related to microbial quality, so they are also described and discussed in Section 6.3 together with microorganisms. These physical parameters all change with time so ideally should be determined at the sampling point.

#### ***Colour or appearance***

This parameter is of concern because it affects acceptability of the water to the consumer. It can indicate the presence of other pollutants such as metals (e.g. iron), organic acids (e.g. from decaying vegetation), suspended solids or industrial wastes (e.g. from tannery or textile processing). Some colour, especially organic, can be difficult to remove without tertiary treatment such as activated carbon.

Natural colour in water tends to be yellow/brown and may be associated with increased turbidity. For boreholes, changes in colour over a period of time may indicate corrosion of the rising main (if metallic) as natural colour of (deep) groundwater is not prone to significant change with time. For shallow groundwater and surface water, changes in the short-term are generally indicative of contamination either due to rainfall or anthropogenic pollution sources, and indicate a need for remedial action. Changes in colour with time should be investigated through more detailed analysis. If a survey indicates that industrial pollution is the cause then a laboratory capable of detailed chemical analysis will need to be identified.

Monitoring colour may be through observation only (simple and virtually cost-free) or by colour measurement using a light box or a spectrophotometer and standards (e.g. Hazen units or platinum colour units). In the first case, a qualitative assessment of the appearance of water would be made (clear, cloudy, murky etc.), whilst in the second case a quantitative assessment is made.

There is no WHO health-based guideline value for colour. It is considered that levels of colour below 15 TCU are usually acceptable to consumers, but acceptability may vary (WHO, 2011a). Although this parameter does not provide information about specific chemicals in water, it can act as a good indicator of water quality problems, particularly when it changes with time. Because of this, and because of the ease and cost of assessment, it is recommended as a parameter in all levels of assessment. In basic/initial assessments, a qualitative assessment of appearance is adequate, but quantitative assessment should be made in higher level assessments. Colour or appearance should be tested on all water samples taken. The five-point scale developed for use in basic/initial assessments is qualitative, with samples being classed as: clear, clear but coloured, slightly cloudy, cloudy or dirty/opaque (usually with sediment present).

#### ***Odour and taste***

Taste and odour can originate from natural inorganic and organic chemical contaminants and biological sources or processes (e.g. aquatic microorganisms), from contamination by synthetic chemicals, from corrosion or as a result of problems with water treatment (e.g. chlorination) (WHO, 2011a). Water should be free of tastes and odours that would be objectionable to the majority of consumers. They can lead to customer dissatisfaction and complaints and may also require an

additional treatment process for their removal from raw waters. If consumers complain about either of these parameters further assessment of water quality is recommended. Although odour does not provide information about specific chemicals in water, it may be considered as an indicator of water quality problems, particularly if it changes with time. Experienced analysts can use odour to identify possible types of pollution (to be confirmed by quantitative analysis).

There are no WHO health-based guideline values for odour and taste but the water should not be objectionable to consumers. It is inadvisable to taste water of unknown chemical and/or microbial quality. Therefore, its inclusion in basic/initial assessments as a core parameter is not recommended. Odour, however, is recommended as a parameter in all levels of assessment because it is virtually cost-free and a good indicator of water quality problems. In basic/initial assessments, a qualitative assessment of whether or not the water is objectionable is sufficient. Odour should be tested on all water samples taken.

### ***Conductivity***

Conductivity, the ability of water to carry an electric charge, can be considered a proxy indicator of total dissolved solids (TDS) and, therefore, of its taste and salinity which primarily comprise inorganic salts (principally calcium, magnesium, potassium, sodium, bicarbonates, chlorides and sulfates). Conductivity is, therefore, an indicator of the taste or salinity of the water. Whilst there is little direct health risk associated with this parameter, high values are associated with poor taste, and hence customer dissatisfaction and complaints. Changes in conductivity with time and high conductivity values can indicate contamination of the water (e.g. saline intrusion, sometimes faecal pollution or nitrate pollution) and can cause corrosion in rising mains and pipes. In this situation, further analysis of the water is recommended.

There is no WHO health-based guideline value for conductivity but it is generally considered that drinking-water becomes significantly and increasingly unpalatable at levels greater than 1400  $\mu\text{S}/\text{cm}$  (being equivalent to a total dissolved solids value of approximately 1000 mg/l) (WHO, 2011a). Although this parameter does not provide information about specific chemicals in water, it can act as a good indicator of water quality problems, particularly when it changes with time. It is recommended as a parameter in all levels of assessment because of this, together with the ease and cost of assessment. A variety of inexpensive field and lab-based equipment is available for this. Conductivity measurements should be made on all water samples taken for analysis.

### ***pH***

The pH ('potential Hydrogen' ion concentration) of a solution is the negative common logarithm of the hydrogen ion activity:  $\text{pH} = -\log(\text{H}^+)$ . The pH of raw water typically lies within the range 5.5–8.5. It is of major importance in determining the corrosive qualities of water: the lower the pH, the higher the potential for corrosion. pH can affect the degree of corrosion of metals (e.g. in down-pipes and in plumbing systems). Importantly, pH is one of the most important operational water-quality parameters. For effective disinfection with chlorine, the pH should preferably be  $< 8$ . The pH of the water entering the distribution system must be controlled to minimize the corrosion of water mains and pipes in household water systems. The optimum pH required will vary in different supplies according to the composition of the water and the nature of the construction materials used in the distribution system, but it is usually in the range 6.5–8.5. Failure to control pH can result in both microbial and chemical contamination of drinking-water, and in adverse effects on its taste, odour, and appearance.

The pH of an aqueous sample is usually measured electrometrically with a glass electrode. Temperature has a significant effect on pH measurement so the temperature of the sample should also be recorded. There is a wide variety of field and lab-based pH meters (some with temperature



compensation), including pocket meters for easy use in the field. pH can also be measured colorimetrically using a comparator or photometer.

There is no WHO health-based guideline value for pH. Because of the impact of pH on the effectiveness of disinfection and corrosion effects, it is recommended that pH be included at all levels of assessment as a core parameter. Tests should be performed on all samples taken from water sources. For basic/initial assessments a pH range of 6.5-8.5 is recommended (WHO, 2011a).

### ***Turbidity***

Turbidity is a measure of the water's ability to scatter and absorb light. It is caused by the presence in water of particulate organic and inorganic matter, such as clay, silt, colloidal particles, and microscopic organisms. Soil particles constitute the major part of the suspended material in most natural waters; consequently surface waters are generally more turbid than groundwater. Raw water turbidity has been reported to range from less than 1 to more than 1000 NTU whereas it is usually <1 NTU in filtered waters.

Turbidity can also have a negative impact on consumer acceptability of water as a result of visible cloudiness. The turbidity of water is related to or affects many indicators of drinking-water quality. For example, there is a relationship between high turbidity and the appearance, colour, taste, and odour of both raw and filtered waters. It is an important indicator of the possible presence of contaminants that would be of concern to health.

Turbidity can have a significant effect on the microbial quality of drinking-water. Its presence can interfere with the detection of bacteria and viruses in drinking-water. More importantly, turbid water has been shown to stimulate bacterial growth since nutrients are adsorbed on to particulate surfaces, thereby enabling the attached bacteria to grow more rapidly than those in free suspension.

Turbidity has no direct health impact but consumption of highly turbid water may constitute a health risk due to the risk of microbial contamination. The major problem associated with turbidity is its effect on disinfection because it can protect pathogenic microorganisms from the effects of disinfectants, stimulate the growth of bacteria in distribution systems, and increase chlorine demand. Turbidity in distribution systems can occur as a result of the disturbance of sediments and biofilms but is also from the ingress of dirty water from outside the system.

A number of methods may be used to measure water turbidity, but nephelometry and turbidimetry form the basis of present standard methods. A variety of inexpensive field and lab-based equipment is available for this. For initial/basic assessments either a turbidity tube or meter is recommended.

There is no WHO health-based guideline value for turbidity but, because of its effects on the removal of microorganisms in treatment and disinfection, it is recommended that turbidity be kept as low as possible (<1 NTU for chlorinated supplies). Aesthetically, water with a turbidity <5 NTU is usually acceptable to consumers (WHO, 2011a). It is recommended that turbidity be included at all levels of assessment as a core indicator. Tests should be performed on all samples taken from water sources.

## ***7.4 Chemical parameters***

The chemical parameters included as core and optional parameters are detailed in Table 7.1. Chemical parameters that are either not easy to determine in the field (e.g. organics) or not widespread should not be included as core parameters. They are therefore recommended for inclusion in higher level assessments and are not described below.

### ***Arsenic***

Arsenic is an element that is known to bio-accumulate in humans (as well as being subject to bio-amplification up the food chain) and is associated with skin disease, heart disease, cancers and a number of other ill-health effects. Arsenic in drinking-water at any concentration, is toxic in the long-term and is associated with skin disease and cancers.

Whilst most arsenic in water is naturally occurring, being derived from dissolution of arsenic-bearing minerals, it may also be anthropogenic, being associated with mining and other industries. It became one of the principal global water quality issues in the late 1990s because of its (increasing) presence in groundwater in Bangladesh and neighbouring countries. Prior to the development of this situation in Asia, data on the presence of arsenic in water were limited, mainly because of the need for laboratory-based, sophisticated equipment for arsenic determination at low concentrations. Recently new laboratory and field methods have been developed and these are helping to clarify the extent of arsenic presence in water world-wide, which appears to be extensive in Asia and Latin America.

For arsenic, WHO has set a provisional health-based guideline value of 10 µg/l (WHO, 2011a). Because of its health significance it is recommended that arsenic is included in basic/initial rapid assessment. Tests should be performed on all samples taken from water sources. If higher level assessments are undertaken, quantitative analysis for arsenic should be included unless there is good evidence to suggest it will not be present.

### ***Fluoride***

Ingestion of excess fluoride is associated with dental and skeletal fluorosis that may cause severe deformation and disability in susceptible individuals, a situation that occurs in many countries world-wide, particularly in parts of India, China, Central Africa and South America, but high concentrations can be encountered locally in most parts of the world. If no data on the presence of fluoride in water are available it should always be suspected if people have mottled teeth or skeletal deformities. However, a lack of fluoride is also associated with dental caries and therefore in some countries fluoride is added to drinking-water to improve dental health. Further information can be found in Fawell *et al.* (2006). Although fluoride may be released by industrial pollution, the majority of fluoride found in drinking-water supplies at levels of health concern is derived from natural sources (e.g. fluoride-containing minerals). Fluoride should always be analysed during source development, in particular for groundwater sources.

Fluoride can be determined in the field using a spectrophotometer or colour comparator; it can be determined by these methods in the laboratory or by use of ion-specific electrodes.

For fluoride, WHO has set a health-based guideline value of 1.5 mg/l (WHO, 2011a). There are significant health effects of long-term exposure to fluoride in water. Because of its health significance it is recommended that fluoride is included in basic/initial rapid assessment. Tests should be performed on all samples taken from water sources. If higher level assessments are undertaken, fluoride should be included unless there is good evidence to suggest it will not be present.

### ***Nitrate***

Nitrate is one of the most ubiquitous chemical contaminants of water bodies world-wide as it is derived from human activities, particularly from the disposal of human and animal wastes and the use of inorganic fertilisers in agriculture. Nitrate is of concern because of its link to methaemoglobinaemia or 'blue-baby' syndrome. Although the actual health burden from nitrate is often considered relatively insignificant (because of breast-feeding practices etc.), it is likely that the health burden is under-reported.

Nitrate is also of particular concern because of its conservative nature in water. Once nitrate has entered a water body that is oxidising, only the processes of dilution and hydrodynamic dispersion are likely to cause significant reductions in concentrations until the input load is reduced. Thus, if the nitrate concentration is allowed to build up in source waters, then long-term resource problems may result from the need for costly investments in treatment. As it is extremely expensive and difficult to remove nitrate during treatment, blending nitrate-rich waters with low nitrate waters may be the only viable option.

Nitrate concentrations should either be determined on-site or samples should be fixed for transport to the laboratory for analysis because nitrate may be converted to nitrite and then to ammonia in non-oxidising water. As there are a number of field methods available for determination of nitrate (e.g. the chemical strip test, colour comparator method, photometric and spectrophotometric methods), field determination is recommended. Use of nitrate-specific electrodes is not recommended because of the relative complexity of the method and its variable sensitivity.

For nitrate, WHO has set a health-based guideline value of 50 mg/l (WHO, 2011a). Nitrate should be included at all levels of assessment as a core parameter. Tests should be performed on all samples taken from water sources.

### ***Iron and manganese***

Both iron and manganese may cause rejection of water by consumers because of taste or the colour that develops when iron oxidises into the ferric state and when manganese oxidises into the manganic state. Iron and manganese cause colouring of clothes and sanitary ware. Iron contamination is a particular problem with groundwater supplies and is usually due to the oxidation of ferrous iron in the water itself, because of corrosion of galvanised iron riser pipes and in some cases from iron bacteria. Some surface waters also have iron problems, particularly related to colloidal iron.

Manganese is most commonly associated with surface water sources where water is pumped from lower levels and the bottom sediment is disturbed. The analysis of iron and manganese is best carried out at the treatment works or wellhead. Testing of distributed waters is likely only to be done in response to complaints, or where there are old galvanised iron mains pipes.

As there are a number of field methods available for determination of iron and manganese (e.g. the chemical strip test, colour comparator and spectrophotometric methods), and because iron may precipitate out of solution with time, field determination is recommended.

There are no WHO health-based guideline values for either manganese or iron (WHO, 2011a). Iron and manganese are mainly of importance to consumer acceptability. At iron levels above 0.3 mg/l iron stains laundry and plumbing fixtures; below 0.3 mg/l there is usually no noticeable taste of iron. Manganese concentrations below 0.1 mg/l are usually acceptable to consumers. Iron and manganese from natural sources normally occur together, therefore monitoring for one could be used as an indicator of possible problems with both parameters. It is recommended that iron be a core parameter for the basic/initial assessment because of the impact on aesthetic quality and also because of its presence (and potential problems) in some rising mains and pipes. Water treatment processes for the removal of iron also remove manganese; however, if manganese is known to be of particular concern then it may also be added to basic/initial assessments. Tests should be performed on all samples taken from water sources and in households.

### ***Chlorine residual***

Chlorine residuals are only present where chlorination is used to disinfect supplies to protect potability during distribution and/or storage. It is present in most disinfected drinking-water at

concentrations in the range of 0.2-1 mg/l. Although they may have an impact on the acceptability of water, they are primarily related to microbial rather than chemical quality (see also Chapter 5).

For chlorine, WHO has set a maximum health-based guideline value of 5 mg/l (WHO, 2011a). For chlorine residual, WHO recommends a value of 0.5 mg/l after treatment (at pH <8.0 and minimum contact time of 30 minutes) and a minimum value of 0.2 mg/l at the point of delivery. Determination of chlorine residual is recommended as a core parameter to be determined for all samples from disinfected supplies (at treatment works, in distribution and in households).

### *Optional chemical parameters*

#### *Aluminium*

Aluminium in drinking-water is usually derived from poor operation of coagulation-flocculation-settling steps in water treatment leading to carry-over of micro-flocs into final waters. Aluminium may also occur naturally or result from industrial effluents. Testing of aluminium in drinking-water is primarily justified in terms of treatment efficiency monitoring. Aluminium in water affects consumer acceptability (i.e. taste and appearance).

Aluminium can be determined in the field using either a photometer or colour comparator or in the laboratory by atomic absorption spectrophotometry.

There is no WHO health-based guideline value for aluminium. Aluminium is mainly of importance to consumer acceptability; concentrations in excess of 0.2 mg/l may lead to consumer complaints. It is recommended that aluminium only be included in basic/initial assessments if there is significantly high concern about its presence from natural sources or from breakthrough from inadequate treatment facilities, otherwise it should only be included in higher level assessments.

#### *Ammonia*

The term ammonia includes the non-ionized (NH<sub>3</sub>) and ionized (NH<sub>4</sub><sup>+</sup>) configurations. Ammonia in the environment originates from metabolic, agricultural, and industrial processes and from disinfection with chloramine. Natural concentrations in ground and surface waters are usually below 0.2 mg/litre but anaerobic ground waters may contain up to 3 mg/litre. Ammonia in water is an indicator of possible bacterial, sewage, and animal waste pollution (WHO, 2011a).

Ammonia can compromise disinfection efficiency, result in nitrite formation in distribution systems, cause the failure of filters for the removal of manganese, and cause problems with taste and odour. There are simple field photometric methods for quantitative determination of ammonia.

There is no WHO health-based guideline value for ammonia. Ammonia is mainly of importance to consumer acceptability; concentrations in excess of 1.5 mg/l may lead to odour problems. As ammonia in drinking-water is not of immediate health relevance, it is not recommended as a core parameter for basic/initial assessments. However, countries where there are concerns on the impacts of ammonia on treatment or in distribution may wish to include it as a parameter for basic/initial assessments.

#### *Copper*

The most significant health effects from copper are gastrointestinal bleeding and renal failure at high doses, and nausea and diarrhoea at lower doses. In addition to these impacts, copper affects acceptability of water as it imparts both taste and colour at concentrations >2.5 mg/l and causes staining of laundry and sanitary wares at concentrations >1 mg/l. Copper concentrations in water supplies range from ≤0.0005 to >30 mg/l, the higher concentrations usually being associated with

corrosion of interior plumbing. Food may be an important source of copper, but drinking-water remains the most significant source. This is usually derived from pipes used in household plumbing systems and solders that contain copper. However, there are natural sources of copper in groundwater and some industrial discharges may also contain copper.

There are simple field photometric methods for quantitative determination of copper at the guideline value, although laboratory-based atomic absorption spectrophotometry (or method of equivalent high sensitivity) is required for low concentrations.

For copper, WHO has set a health-based guideline value of 2.0 mg/l (WHO, 2011a). There are significant health effects of both short and long-term exposure to copper in drinking-water within piped systems, especially where copper piping is used and waters are acidic and/or aggressive. Consequently copper is recommended as an optional parameter in basic/initial assessments but only for piped supplies. Analysis should be performed on all such sources and within distribution systems and household waters.

### ***Lead***

The most significant health effect from lead is the association of lead exposure with reduced cognitive development and intellectual performance in children. Although other environmental transmission routes such as air and food may be important, drinking-water can be a significant reservoir of lead. This is usually derived from lead pipes used in household plumbing systems and lead solders; and in some cases where lead has contaminated treatment chemicals. There are also natural sources of lead in groundwater and some industrial discharges may contain lead as well.

There is no simple field method for quantitative determination of lead at concentrations normally occurring in water supplies: atomic absorption spectrophotometry (or a method of equivalent high sensitivity) is required.

For lead, WHO has set a provisional health-based guideline value of 0.01 mg/l (WHO, 2011a). There are significant health effects of long-term exposure to lead in water. However, the laboratory-based assessment method required supports the recommendation that it is included in higher level assessments only. In countries where lead is known or strongly suspected to exist and with the internal capacity for quantitative analysis, it may be considered in initial/basic assessments. Lead should always be included in higher level assessments, unless there is good evidence to suggest it will not be present. Tests should then be performed on all samples taken from water source types and distribution systems, including households receiving piped water, in areas suspected to have lead-contaminated water.

## ***7.5 Equipment recommendations***

For basic/initial assessments, the available field equipment should be adequate to undertake all the necessary physical and chemical analysis required. Photometers or colour comparators are generally preferred to spectrophotometers as they are cheaper and more portable. Where it is appropriate, hand-held meters may also be used for certain physical parameters. The field methods suitable for basic/initial rapid assessments are outlined in Table 7.1.

For basic/initial level assessments field-based analytical methods and tools will be adequate for all the core parameters and for the majority of the optional parameters that may be locally significant. However, there may be either a need (e.g. heavy metals) or a country preference for laboratory-based analysis. This requires adequate infrastructure (e.g. laboratories, transport etc.) to ensure samples do not deteriorate between collection and analysis. Use of field analysis is recommended where transport is difficult or lengthy, and laboratory facilities are limited, but for higher level

assessments a mixture of field and laboratory based methods will generally be required. If a mixture of field and laboratory methodologies are to be used for the same parameter it will be necessary to confirm that results are consistent.

## 8 DATA MANAGEMENT, ANALYSIS AND USE

The analysis of water quality data is the principal mechanism by which raw data can be transferred into usable information for managers, water supply operators, surveillance agencies, communities and other decision-makers. Raw data alone are of relatively little use – most people will not understand what they mean unless they have been directly involved in their collection and few will have sufficient time or interest to analyse data. What is required is simple, direct and comprehensible information that can be used without further manipulation and is meaningful to the target audiences. Data analysis should, for example, identify common risks to water quality and provide recommendations on remedial actions at operational or strategic levels.

Meaningful analysis of the data is therefore very important for the RADWQ report and dissemination of assessment findings but equally important is the quality (and quantity) and relevance of data collected. A suggested contents list for the final report is given in Annex 7 – these should include the background to the study area, the purpose of the survey/assessment and selection of indicators and methodologies, as well as presenting the data with appropriate analysis, interpretation and recommendations.

### 8.1 Data requirements

Detailed decisions need to be taken during the survey design phase and prior to starting the fieldwork on both the types and amounts of data to be collected and the mechanisms for both their management and their analysis. The types of decisions that will ensure information collected meets the requirements for data entry and analysis in the software programme selected are presented in Table 8.1.

**Table 8.1: Raw data and data analysis requirements**

Data/action requirement	Comment
Water supply technologies to be covered	<p><u>Basic/initial RADWQ</u>: All “improved” technologies supplying <math>\geq 5\%</math> of the population (national or regional)</p> <p><u>Other RADWQ</u>: Inclusion of “unimproved” water sources to enable comparison of water quality with “improved” sources (e.g. comparing both protected (“improved”) and open (“unimproved”) dug wells)</p>
Indicators/parameters to include to meet the required outcomes	<p><u>Basic/initial RADWQ</u>: Microbial, physical and chemical parameters and sanitary inspections as per Table 2.2</p> <p><u>Other RADWQ</u>: To investigate a specific water quality issue, possibly temporal, spatial, technology or parameter specific (e.g. focus on arsenic or microbial quality to compare between “improved” and “unimproved” sources; or focus on single technologies to compare appropriateness in different regions/communities)</p>
Degree of accuracy for readings	<p><u>Basic/initial RADWQ</u>: Number of significant figures varies with analytical method and parameter but accuracy must be sufficient to determine whether WHO guideline values and/or national standards are met</p> <p><u>Other RADWQ</u>: May require high accuracy (e.g. close to an existing guideline value when this is under review) or may require low accuracy if absences/presence is sufficient (e.g. parameter of technical rather than health significance)</p>

<b>Data/action requirement</b>	<b>Comment</b>
Equipment for laboratory or field analysis	<u>Basic/initial RADWQ</u> : Field analysis is recommended for <b>all</b> parameters; accuracy/precision of equipment needs to be taken into account when determining error margins during data analysis <u>Other RADWQ</u> : Sampling logistics or inclusion of parameters requiring high accuracy may favour laboratory analysis (e.g. may be determined by number and geographical spread of laboratories) or no appropriate field method is available (e.g. lead)
Inclusion of sanitary inspections and/or environmental risk appraisals	<u>Basic/initial RADWQ</u> : Sanitary inspections are recommended at all sampling points <u>Other RADWQ</u> : May focus on environmental risk appraisals (e.g. if no microbial parameters are to be included in the assessment)
Information detail on sample point locations	<u>Basic/initial RADWQ</u> : Broad area, cluster number and sample number included in the unique WSS sample number, with possible other information on written records (such as local government area or community names) <u>Other RADWQ</u> : If equipment is available, include GPS readings; or, if interest is only be down to broad area level, it is generally recommended that more detailed information is recorded as this may be of future use
Method for allocation of unique sampling number/label	<u>Basic/initial RADWQ</u> : As per Chapter 4, an eight-character identification number is recommended, giving country three characters, broad area one character, cluster number two characters and sample number two characters (e.g. ROS21325 for <i>Republic Osmiga</i> , broad area 2, cluster number 13, sample number 25) <u>Other RADWQ</u> : May be dictated by the software programme in use
Method for management of quality control data	<u>Basic/initial RADWQ</u> : Given specific identifier in the sampling number <u>Other RADWQ</u> : May be dictated by the software programme in use NB: It is essential that this data set is removed for data analysis but can be used to assess performance of equipment and field teams.
Methods for recording raw data (analytical and risk assessment)	<u>Basic/initial RADWQ</u> : Specifically designed record sheets and analysts' log books <u>Other RADWQ</u> : May be specific local/national requirement or preference (e.g. direct entry into database in field laptops) Both: Need to establish rules for default entries for recording of non-numerical values (see below)
Appointment of a data manager and other team members	<u>Basic/initial RADWQ</u> : One person should be designated by the intersectoral management team as responsible for data management and handling; this person (the data manager) should also be given overall responsibility for data analysis <sup>(a)</sup> <u>Other RADWQ</u> : Either by specific local/national requirement or preference using established working procedures (if in place) or appoint a data manager
Communication strategy between field and data management teams	<u>Basic/initial RADWQ</u> : Weekly posting (by courier or fax) of record sheets to data manager (with analyst logbook back-up) <u>Other RADWQ</u> : By specific local/national requirement or preference using established working procedures, if in place (e.g. electronic transfer of data files with hard-copy backup)
Software program(s) to be used	<u>Basic/initial RADWQ</u> : Pilot used "SanMan" (commercially available, customised for RADWQ) and Microsoft Excel <u>Other RADWQ</u> : By specific local/national requirement or preference (e.g. organisation or country-specific)



<b>Data/action requirement</b>	<b>Comment</b>
Establish rules for data entry	<p><i>Basic/initial RADWQ and other RADWQ:</i> It is essential to define default entries for samples where there is no definite numerical value; examples include:</p> <ul style="list-style-type: none"> <li>- for coliform counts of &lt; 1 a default value of 0 can be used;</li> <li>- for coliform counts that are too numerous to count (TNTC) a default value of 100 can be used<sup>(b)</sup>;</li> <li>- for chemical and physical parameters where no or only a trace is detected the default is 0<sup>(c)</sup>;</li> <li>- where no analysis was undertaken the default is either a blank field (if the data programme allows this) or a designated number (e.g. 9999);</li> <li>- where a 'trace' was detected (default will depend on the parameter);</li> <li>- subjective values (e.g. clear/cloudy for appearance of water)</li> </ul>
Clean data set	<p><i>Basic/initial RADWQ and other RADWQ:</i> It is essential to obtain a clean data set before data analysis is started; this should be managed by the data manager in consultation with the field teams (see Section 8.2.2)</p>

- (a) By preference, this person should be a statistician involved in the design of the study and should be consulted prior to the start of the fieldwork, to ensure that all data requirements are addressed early in the project as it will be difficult, if not impossible, to fill data gaps after completion of the field work.
- (b) One crucial point to remember when analysing water quality data is that the microbial data are unlikely to follow a normal distribution and will have a considerable number of 'outliers' (very high or low values). This may include tests that give a result that is too numerous to count (TNTC), such results should be assigned a default value which is higher than the maximum countable result (usually ~100).
- (c) Similar to (b), chemical data may have a significant number of samples with results below the level of detection (assigned 0) or, less frequently, very high values when values are usually measurable only after sample dilution, which can decrease accuracy – these can be assigned a default value which is higher than the maximum detectable result, WHO guideline value or national standard. The default value will, therefore, be parameter specific.

The software program(s) selected for data storage and analysis will need to meet the requirements of the survey. For the basic/initial assessments covered in this manual it may be appropriate to use a readily available spreadsheet programme as this is easily formatted to provide sufficient structure and detail (see Section 8.3). Most organisations have people skilled in their operation, plus it is normally available in a local language. However, more complex software already available and in use in the organisation(s) undertaking the assessment could also be used. For higher level assessments software specifically designed for storage and analysis of detailed/extensive (spatial and temporal) water quality data would be more appropriate.

Either the person with overall responsibility for data management (see Section 8.2) or another member of staff within the data management team should be responsible for quality control in the input of data to the software programme selected. This will involve checking that data input has been accurate. Liaison with fieldwork teams will be required when producing the final 'clean' data set to resolve any water quality queries, such as anomalous readings for individual indicators/parameters or unusual regional/temporal variations in data (see Section 8.2.3).

## **8.2 Data management**

The section discusses minimum requirements suitable for management and analysis of data from basic/initial RADWQ surveys. For higher level assessments, they could be incorporated into existing processes within the implementing agencies, as appropriate.

### **8.2.1 Data management team**

Management of computer data bases requires personnel with relevant expertise of both data entry and analysis. The inter-sectoral management team should appoint a data manager early in the

planning process to ensure s/he can advise on the selection of the database system to be used for data storage and analysis, the format of data for entry to the database, the design of the communication strategy (e.g. from field teams to data management team and from data management team to the intersectoral management team) and the requirements for data analysis and reporting. Ideally the data manager should also have experience or an understanding of issues relating to water quality data as this will assist with recognition of anomalies in both raw and entered data and facilitate preparation of a clean data set (see below in Section 8.2.3) prior to data analysis. This would also enable the data manager to undertake a role in supporting the fieldwork teams by visiting them during the data collection period and also providing telephone support to field teams on actions when data anomalies occur in the field or are noted during entry of weekly data sets.

The inter-sectoral management team should, where possible, assign additional members to the data management team to assist with data entry and analysis to speed up the process and support the data manager. This is especially important if the data manager is also undertaking the roles of paying visits to field teams (for quality control and support) and liaising in the inter-sectoral management team. Appropriate training should be given to the data management team as it is essential that the quality and accuracy of data entry is consistent, especially in relation to use of default values and designated numbers for indicators/parameters for which no or only a trace is detected or TNTC entries in contrast to no entry for samples for which no analysis was undertaken (see also Table 8.1).

Data entry can be facilitated by use of networked computers with varying levels of access (e.g. entry of new data only or ability to alter and correct existing data) with the data manager having full access to all programme components (from data entry to data analysis and report production). The data manager also needs to ensure that daily back-up files are stored (on CD or external drives; ideally stored overnight in a separate room or building) so that, should a computer fail, the data are not lost. At least one (other) member of the inter-sectoral management team needs to have full access to the database (in case the data manager is incapacitated).

### ***8.2.2 Communication strategy during field implementation and data analysis***

The data manager will need to liaise with field teams on transfer of data from the field to the data management team. For basic/initial RADWQ surveys it is recommended that hard copies of field data are sent weekly (by courier/speed post or fax) to the data management team. Field teams should back-up the data in their logbooks. If local facilities and resources for photocopying are available, copies of the field record sheets could be made and retained by the field teams. The data manager will need to contact field teams if data sets are overdue to identify reasons and, if necessary, to advise on actions required. Whilst data entry directly into the database is possible in the field it is not recommended for basic/initial RADWQ surveys unless this system is already successfully established. Some of the reasons for this recommendation are the costs of the computers, their reliability under field conditions (e.g. transport, terrain and climate) and the time, cost and coordination required for additional training of field teams in data entry and management. However, recent developments of communication strategies based on personal digital assistants or smart phones may allow reliable remote communication between field and data management teams.

If the data manager is not a member of the inter-sectoral management team, s/he will need to have an agreed reporting mechanism and frequency for communicating information to the team and for resolving any issues on data collection and management. The team may designate one of its members for this communication responsibility to speed up any urgent decisions (especially when feedback to field teams is required during the data collection phase). In addition, decisions will need

to be agreed early in the project for the type of and format of information that the data manager will need to provide to the team and for the final report.

### 8.2.3 Obtaining a clean data set

Before analysing data it is essential to ‘clean’ the datasets to correct anomalies and to identify any missing data. This will require collaboration between the field and data management teams. Field teams should use their logbooks and expert judgement to assist the data manager in this process, especially where the data manager has limited expertise relating to water quality analysis. For instance, the field team will be able to determine whether a value is plausible or has been incorrectly recorded (in the field or during data entry) and advise on any corrections to (or omissions of) data. Reviewing data should not be confined to the post-collection period but should be on-going during the fieldwork as some anomalies (e.g. due to problems with equipment, chemical analyst errors, or indicators of local water quality issues) can be identified and recorded and appropriate actions taken as soon as possible. This action may include increasing the frequency of quality control analysis for some indicators/parameters, increasing the frequency of equipment calibration, or revision training of analysts. The tight schedule in the field work does not normally allow time to return to sites for retesting, so it is essential that data are reviewed frequently so that any remedial action can be promptly implemented. Such action during fieldwork will facilitate data cleaning, and also reduce the amount of data that is absent or has to be omitted because of inaccuracies.

Data for the *Republic Osmiga* given in Box 8.1 are used to illustrate some examples of the errors and anomalies that may need to be resolved when preparing a clean data set.

<b>Box 8.1: Worked example – Cleaning the data set</b>									
In the <i>Republic Osmiga</i> , field data were entered in an electronic database, as shown in excerpts in the table below.									
The data management team carried out a step-wise quality check of the raw data entered. Examples of data errors or anomalies encountered are given below the table.									
Row	WSS-No.	TTC count	pH	Conductivity	Turbidity	Appearance	As (mg/l)	Fe (mg/l)	F (mg/l)
1	ROS53101	0	7.12	720	0.49	Clear	<0.01	0	0.35
2	ROS53102	0	7.12	760	0.90	Clear	<0.01	0	0.40
3	ROS53103	0	7.12	700	1.27	Cloudy	<0.01	0	0.40
4	ROS53104	0	7.12	710	1.00	Clear	<0.01	0	0.55
5	ROS53105	<1	7.12	720	0.29	Clear	<0.01	trace	0.05
6	ROS53106	-	7.12	710	0.15	Clear	<0.01	0	0.95
7	ROS53107	5812	7.12	720	0.63	Clear	<0.01	0	0.55
8	ROS58108	0	7.21	720	1.00	Clear	<0.01	0	0.70
9	ROS53109	TNTC	7.21	720	163.00	Clear	<0.01	trace	2.75
10	ROS53110	0	7.21	720	1.00	Cloudy	<0.01	0	0.50
11	ROS63101	0	7.12	715	0.30	Clear	<0.01	0	0.70
12	ROS63102	-	7.12	730	0.58	Clear	<0.01	0	0.25
13	ROS63103	5	7.12	715	0.20	Clear	<0.01	0	0.35
14	ROS63104	3	4.20	730	0.70	Clear	<0.01	0	0.30
15	ROS63150	0	7.12	730	0.60	Clear	<0.01	0	0.30
16	ROS63106	-					<0.01	0	0.35
17	ROS63106	0	7.21	700	0.60	Clear	<0.01	0	0.35
18	ROS63107	-	7.21	710	0.65	Clear	<0.01	0	0.50
19	ROS63108	0	7.12	660	0.40	Clear	<0.01	0	0.50
20	ROS63109	0	7.12	830	0.47	Clear	<0.01	0.55	0.55

### Box 8.1: Continued

- 1 Rules for the entry of zero, absent or trace readings have not been applied:
  - *Thermotolerant coliforms (TTC) count.* The database shows entries of “< 1”, “TNTC” and “-“. These need to be checked against the original data and the agreed default values entered into the database. In the *Republic Osmiga*, default values defined include “0” for “< 1” and “100” for “TNTC”; the designated number “9999” is to indicate that no sample was taken (i.e. “-“). In line 7, the entry of “5812” is obviously incorrect; thus the data manager would need to crosscheck the records and/or contact the responsible field team to clarify the mistake.
  - *Arsenic and iron.* The database shows entries of “< 0.01” for arsenic and two ”trace” entries for iron. According to the default values defined in the *Republic Osmiga*, these values equate to an absence of arsenic or iron, and thus database entries would need to be adapted to “0”.
  - *Appearance.* The database shows entries of “clear” and “cloudy”. A numerical default system needs to be established for the five categories of appearance, and the database needs to be changed accordingly.
- 2 Plausibility checks:
  - *Possible typing or transposition errors.* In line 1, the entry for conductivity is “720” instead of “720” which may lead to difficulties in data analysis. Also, the entry for appearance is “cleary” instead of “clear”.
  - *Possible typing or transposition errors.* In lines 8 and 15, WSS-Nos. seem to be out of order, and it would be necessary to check whether the numbers should be ROS53108 (rather than ROS58108) and ROS63105 (rather than ROS63150), respectively.
  - *Parameter values.* In line 20, WSS-No. ROS63109 has the same numeric values for iron and fluoride whereas iron is absent in all other samples. This may be correct or a typing/transposition mistake, which should be checked and corrected, if necessary.
  - *Parameter values.* The data entered in line 9 for ROS53109 need to be checked as, in addition to the TNTC entry, the turbidity values is recorded as 163.00 but the appearance is given as clear. If the turbidity value is correct then the appearance may be incorrect (and vice versa). However, in line 10 the turbidity value is recorded as 1 but the appearance is given as cloudy. This may be an error in transposition of data between lines 9 and 10.
  - *Double or missing entries.* There are two records for ROS63106 and one of the two records has very limited data entered. It would be necessary to check and delete one of the two records, taking care not to delete the record that contains the correct water quality data (and the associated sanitary inspection form).
- 3 Other data checks include checking:
  - of the completeness of sanitary inspection forms and that the numbers match those for water quality data;
  - that technology categories and WSS-Nos. (using the cluster characters) match;
  - of cluster codes in the WSS-Nos. and that associated household samples are the same; any difference would need to be checked against the raw data (to see if it is a typing error) or with the field analysts (to see if it is a field recording error); and
  - that clusters do not contain a mixture of technology types as this may indicate an error in data recording.

### 8.3 Data analysis for basic/initial RADWQ surveys

Once a clean dataset has been agreed then data analysis can start. For basic/initial RADWQ surveys the recommended analyses are as follows:

1. *Evaluate water quality (excluding household samples).* For each “improved” water supply technology, calculate nationally and for broad areas (see Section 8.3.1):
  - For the bacteriological indicators (i.e. thermotolerant coliforms), the percentage of samples complying with WHO guideline values and national standards;
  - For bacteriology-related parameters (i.e. turbidity, pH, and chlorine residuals) and physical parameters (e.g. conductivity, odour and appearance), the percentage of samples complying with WHO suggested values and national standards;
  - For individual chemical parameters (e.g. arsenic, fluoride, nitrate, iron and any optional parameters), the percentage of samples complying with WHO guideline values and national standards;

- The percentage compliance with WHO guideline values and national standards from the overall bacteriological and chemical perspective.
2. *Evaluate sanitary integrity (excluding household samples).* For each “improved” water supply technology, nationally and for broad areas, use the sanitary inspection and bacteriological data to (see Section 8.3.2):
    - Identify which sanitary risks are most common.
    - Assess priority supplies for remedial action using the risk-priority-matrix (see Chapter 6);
  3. *Evaluate household water quality.* For all household samples, investigate any deterioration or improvement in water quality in distribution or during household storage by comparing household water microbial and chemical quality with that of the source. Causes of failure can be analysed by the same approaches as for point sources. Calculate percentages of household water samples that are better, worse or equal to source water quality for thermotolerant coliforms, risk-priority categories, nitrate and chlorine residuals (if the water is disinfected). In addition, to investigate possible causes of changes in water quality (see Section 8.3.3):
    - Identify which sanitary risks are most common in household water and see if these are related to changes (if any) in water quality between the source and the household water point;
    - If copper has been detected in household samples, compare the concentrations with the WHO guideline values and national standards, and decide whether an investigation of the source of the copper (e.g. household plumbing) is warranted.

### 8.3.1 Evaluation of water quality

Tables 8.2 - 8.6 provide examples of analysis of water quality data for various individual and combinations of indicators/parameters from two RADWQ pilot countries (Ethiopia and Nigeria). Brief comments below each table represent the types of interpretation of these data that are needed to contribute to data-based recommendations, which are discussed further in Section 8.5 and Chapter 9.

**Table 8.2: Compliance for thermotolerant coliforms by technology type for broad areas and nationally in Ethiopia (Tadesse *et al.*, 2010)**

Broad area	Utility-piped supplies		Boreholes		Protected springs		Protected dug wells		TOTAL	
	Total number of samples	Compliance WHO GV and national standard	Total number of samples	Compliance WHO GV and national standard	Total number of samples	Compliance WHO GV and national standard	Total number of samples	Compliance WHO GV and national standard	Total number of samples	Compliance WHO GV and national standard
Oromiya and Addis Ababa	517	90%	109	72%	80	51%	8	75%	714	83%
Dire Dawa and Somali	70	80%	19	42%	0	-	0	-	89	72%
Tigray and Amhara	171	84%	120	73%	159	50%	127	47%	577	64%
SNNPR	80	86%	42	57%	80	21%	20	100%	222	59%
<b>NATIONAL</b>	<b>838</b>	<b>88%</b>	<b>290</b>	<b>68%</b>	<b>319</b>	<b>43%</b>	<b>155</b>	<b>55%</b>	<b>1,602</b>	<b>72%</b>

*Comment to Table 8.2.* These data for thermotolerant coliforms show failures in compliance for all technologies with large variations between technologies and between broad areas for a single technology. Utility-piped supplies have the highest national compliance (88%) and least variation between broad areas (all  $\geq 80\%$ ), whereas protected springs have the lowest national compliance (43%) and also the lowest for a broad area (21% in SNNPR).

**Table 8.3: Compliance for turbidity by technology type for broad areas and nationally in Nigeria (Ince *et al.*, 2010)**

Broad area	Boreholes		Protected dug wells		Utility-piped supplies		Vehicle tanker supplies		TOTAL	
	Total number of samples	Satisfying WHO suggested values	Total number of samples	Satisfying WHO suggested values	Total number of samples	Satisfying WHO suggested values	Total number of samples	Satisfying WHO suggested values	Total number of samples	Satisfying WHO suggested values
HA 1	75	84%	75	36%	35	6%	0	-	185	50%
HA 2	0	-	25	4%	70	54%	0	-	95	41%
HA 3	0	-	50	76%	0	-	0	-	50	76%
HA 4	50	78%	100	14%	35	43%	0	-	185	37%
HA 5	75	100%	0	-	34	100%	0	-	109	100%
HA 6	224	90%	125	33%	315	64%	29	93%	693	68%
HA 7	0	-	0	-	35	54%	0	-	35	54%
HA 8	100	79%	49	55%	105	33%	0	-	254	56%
<b>NATIONAL</b>	<b>524</b>	<b>87%</b>	<b>424</b>	<b>35%</b>	<b>629</b>	<b>55%</b>	<b>29</b>	<b>93%</b>	<b>1,606</b>	<b>61%</b>

*Comment to Table 8.3.* These data for turbidity show wide variations both between and within broad areas as well as between technologies. Compliance levels of 4% (for protected dug wells in HA2) and 6% (for utility-piped supplies in HA1) are very low. For utility-piped supplies compliance varied between 6% and 100%. Also, an overall compliance of 55% for utility-piped supplies raises questions about the quality of treated water entering the system and/or the integrity of the distribution system. Further analysis of all the data (e.g. do the values comply with a higher but acceptable national value/target or are the values higher than this?) and a review of possible correlations with TTC counts and sanitary risks (see below) would be necessary before recommendations to improve water quality could be made.

**Table 8.4: Compliance for fluoride by technology type for broad areas and nationally in Ethiopia (Tadesse *et al.*, 2010)**

Broad area	Utility-piped supplies		Boreholes		Protected springs		Protected dug wells		TOTAL	
	Total number of samples	Compliance WHO GV and national standard	Total number of samples	Compliance WHO GV and national standard	Total number of samples	Compliance WHO GV and national standard	Total number of samples	Compliance WHO GV and national standard	Total number of samples	Compliance WHO GV and national standard
Oromiya and Addis Ababa	520	87%	110	99%	74	100%	8	100%	712	90%
Dire Dawa and Somali	70	71%	19	95%	0	-	0	-	89	78%
Tigray and Amhara	173	100%	121	100%	159	100%	127	99%	580	100%
SNNPR	89	99%	42	98%	80	100%	20	100%	231	99%
<b>NATIONAL</b>	<b>852</b>	<b>90%</b>	<b>292</b>	<b>99%</b>	<b>313</b>	<b>100%</b>	<b>155</b>	<b>99%</b>	<b>1,612</b>	<b>94%</b>

*Comment to Table 8.4.* These data for fluoride show that, whilst overall compliance is relatively high, some fluoride levels are unacceptable, especially in one broad area (Dire Dawa and Somali) and for utility-piped supplies in another (Oromiya and Addis Ababa). They suggest that fluoride removal options need to be reviewed, especially for utility-piped supplies.

**Table 8.5: Overall compliance for thermotolerant coliforms, arsenic, fluoride and nitrate in Nigeria (Ince *et al.*, 2010)**

Broad area	Boreholes		Protected dug wells		Utility-piped supplies		Vehicle tanker supplies		TOTAL	
	Total number of samples	Compliance WHO GV	Total number of samples	Compliance WHO GV	Total number of samples	Compliance WHO GV	Total number of samples	Compliance WHO GV	Total number of samples	Overall compliance WHO GV
HA1	75	95%	75	61%	35	80%	0	-	185	78%
HA2	0	-	25	100%	70	97%	0	-	95	98%
HA3	0	-	50	58%	0	-	0	-	50	58%
HA4	50	72%	100	53%	35	74%	0	-	185	62%
HA5	75	84%	0	-	35	77%	0	-	110	82%
HA6	225	84%	125	22%	315	66%	29	62%	694	64%
HA7	0	-	0	-	35	77%	0	-	35	77%
HA8	100	93%	49	69%	105	98%	0	-	254	91%
<b>NATIONAL</b>	<b>525</b>	<b>86%</b>	<b>424</b>	<b>51%</b>	<b>630</b>	<b>77%</b>	<b>29</b>	<b>62%</b>	<b>1,608</b>	<b>73%</b>

*Comment to Table 8.5.* These data, for overall compliance considering thermotolerant coliforms, arsenic, fluoride and nitrate, show wide variation on overall compliance both within and between technologies and broad areas. Investigations, including the use of sanitary inspection data, are needed, for example, to explain the low compliance of 22% in HA6 when compared to that in HA2 (100%) for protected dug wells.

**Table 8.6: Summary of compliance with WHO guideline values and national standards by parameter in Ethiopia (Tadesse *et al.*, 2010)**

Parameter	Total (Nationally)	Utility-piped supplies	Boreholes	Protected springs	Protected dug wells
Thermotolerant coliforms (TTC)	72%	88%	68%	43%	55%
Arsenic (As)	100%	100%	100%	100%	100%
Fluoride (F)	94%	90%	99%	100%	99%
Nitrate (NO <sub>3</sub> )	99%	98%	100%	100%	100%
<b>Overall compliance (TTC, As, F, NO<sub>3</sub>)</b>	<b>68%</b>	<b>80%</b>	<b>66%</b>	<b>44%</b>	<b>55%</b>
Iron (Fe)	94%	95%	86%	98%	94%
Turbidity	87%	94%	80%	78%	80%
Conductivity	95%	94%	94%	99%	96%

*Comment to Table 8.6.* These data for overall compliance with WHO guideline values show that the main factor contributing to the levels of overall compliance is the thermotolerant coliform compliance. These data would need to be reviewed together with the sanitary integrity data and the risk-priority matrix (see Section 8.3.2) to inform recommendations.

### 8.3.2 Evaluation of sanitary integrity

The sample risk-priority matrix (see Section 6.5) and overall classification given in Tables 8.7 and 8.8 are based on RADWQ data from Ethiopia. Brief comments below the tables represent the types of interpretation of these data that are needed to contribute to data-based recommendations, which are discussed further in Section 8.5 and Chapter 9.

**Table 8.7: Risk-priority matrix, nationally in Ethiopia (modified from Tadesse *et al.*, 2010)**

TTC count per 100 ml	Utility-piped supplies				Boreholes				Protected springs				Protected dug wells				TOTAL			
	SIRS				SIRS				SIRS				SIRS				SIRS			
	0-2	3-5	6-8	9-10	0-2	3-5	6-8	9-10	0-2	3-5	6-8	9-10	0-2	3-5	6-8	9-10	0-2	3-5	6-8	9-10
<1	288	375	69	0	76	111	10	0	16	91	28	3	46	32	7	0	426	609	114	3
1-10	7	20	6	2	6	16	3	0	8	13	10	1	5	9	3	0	26	58	22	3
11-100	20	22	11	0	8	28	12	0	13	50	25	5	4	22	7	0	45	122	55	5
>100	5	7	3	0	4	13	0	1	4	28	21	3	4	9	7	0	17	57	31	4

Legend for risk-priority categories:

LOW RISK	INTERMEDIATE RISK	HIGH RISK	VERY HIGH RISK
----------	-------------------	-----------	----------------

\* Sanitary inspection risk score (SIRS)

**Table 8.8: Overall risk-priority classification, nationally in Ethiopia (modified from Tadesse *et al.*, 2010)**

Risk category	Utility-piped supplies		Boreholes		Protected springs		Protected dug wells		TOTAL	
	Number of technologies	Proportion	Number of technologies	Proportion	Number of technologies	Proportion	Number of technologies	Proportion	Number of technologies	Proportion
Low risk	288	35%	76	26%	16	5%	46	30%	426	27%
Intermediate risk	402	48%	133	46%	112	35%	46	30%	693	43%
High risk	128	15%	61	21%	126	40%	43	28%	358	22%
Very high risk	17	2%	18	6%	65	20%	20	13%	120	8%

*Comment to Tables 8.7 and 8.8.* The risk-priority data show that about one third (27%) of the water supplies included in the RADWQ study are classified as being at low risk; however, only 5% of protected spring sources were in these categories. In addition, a significant proportion (30%) of all technologies in the study is classified as at high or very high risk. Across the different technologies the proportion of high or very high risk ranges from 17% for utility-piped supplies to 60% for the protected springs. For planning and prioritising individual remedial interventions, the results would need to be reviewed in relation to the specific sanitary risks (see example in Table 8.9) and other water quality data. Generally, “improved” water sources classified as “high” or “very high” in the risk-priority categories should receive higher attention in terms of implementing remedial interventions than technologies classified as “low” or “intermediate” (see also Section 6.5).

Table 8.9 summarises sanitary risk inspection data for mechanical borehole supplies from Nigeria, one of the RADWQ pilot countries. These data, which also could be segregated by broad area, aid identification of most common sanitary risks.



**Table 8.9: Summary of sanitary risk inspection data for mechanised boreholes in Nigeria, nationally (Ince *et al.*, 2010)**

Sanitary risk inspection question (total number of sample: 333)	Risk frequency	
1. Is there a latrine or sewer within 100 m of the pumping mechanism?	115	35%
2. Is there a latrine within 10m of the borehole?	45	14%
3. Is there any source of other pollution within 50 m of the borehole (e.g. animal breeding, cultivation, roads, industry etc)?	133	40%
4. Is there an uncapped well within 100 m?	15	5%
5. Is the drainage channel absent or cracked, broken or in need of cleaning?	103	31%
6. Can animals come within 50 m of the borehole?	115	35%
7. Is the base of the pumping mechanism permeable to water	17	5%
8. Is there any stagnant water within 2 m of the pumping mechanism?	24	7%
9. Is well seal insanitary?	41	12%
10. Is the borehole cap cracked?	28	8%

*Comment to Table 8.9.* The data show that the highest risks to water quality come from the proximity of pollution sources within 50 m, from latrines or sewers within 100 m and from animal access within 50 m. Interventions targeting at the reduction of these most frequent risks may include interventions for (re)siting of boreholes or latrines in relation existing infrastructure, construction of fences and/or educational interventions, respectively. On a larger regional or national scale, sanitary risks found most frequently should generally receive higher attention in terms of planning and implementing remedial intervention programmes than those risks found less frequently.

### 8.3.3 Evaluation of household water quality

By assessing the quality of water stored and used in the home compared to those of the source where the water was obtained, the significance of re-contamination can be evaluated. This can be evaluated further by analysing samples taken from a source, collection vessel and household water storage, which may identify where contamination occurs during the water chain and whether household treatment limits contamination at the point of consumption. The analysis of household water quality will also indicate where the major focus of an intervention strategy is required.

The data presented in Tables 8.10 - 8.12 are based on RADWQ data for Ethiopia. Brief comments below the tables represent the types of interpretation of these data that are needed to contribute to data-based recommendations, which are discussed further in Section 8.5 and Chapter 9.

**Table 8.10: Compliance for thermotolerant coliforms in household water in Ethiopia (Tadesse *et al.*, 2010)**

Technology	Total number of samples	Compliance with WHO GV and national standard
Household piped water	398	85%
Household container	156	44%
Total	554	74%

*Comment to Table 8.10.* Compliance for thermotolerant coliforms is significantly higher for household piped water (85%) than for water from household containers (44%). This may be due to contamination during collection or storage; or possibly to collection from more than one source.

**Table 8.11: Comparison of thermotolerant coliform counts between household and source water in Ethiopia (Tadesse *et al.*, 2010)**

Comparison to TTC count of source water	Household piped water		Household container		Total	
	Total number of samples	Proportion	Total number of samples	Proportion	Total number of samples	Proportion
Lower	13	4%	10	7%	23	5%
Equal	308	84%	62	42%	370	72%
Higher	48	13%	75	51%	123	24%

**Table 8.12: Overall risk-priority classification for household water quality in Ethiopia (modified from Tadesse *et al.*, 2010)**

Risk category	Household piped water		Household container		Total	
	Number of supplies	Proportion	Number of supplies	Proportion	Number of supplies	Proportion
Low	78	20%	12	8%	90	16%
Intermediate	230	58%	50	32%	280	51%
High	78	20%	62	40%	140	26%
Very high	9	2%	31	20%	40	7%

*Comment to Tables 8.11 and 8.12.* Although the majority of household water samples had the same quality as the source water, almost a quarter (24%) of the sites investigated and 51% of household containers show post-source deterioration of microbial water quality. The importance of household containers is also reflected in the risk-priority classification which shows that 60% of household containers can be classified as at “high” or “very high” risk. Review of other water quality data and predominant sanitary inspection risks should help to identify reasons for the post-source contamination for household containers and inform interventions at household level to improve water quality.

#### **8.4 Additional uses of data analysis**

The sanitary risk inspection data, together with the risk-priority data and other water quality data, can be used for further in-depth analysis that may contribute significantly to formulation of recommendations to improve or rehabilitate water supplies and/or inform selection of appropriate technologies nationally, at the regional level or for individual supplies, and to prioritise education interventions aimed at improving the safety of drinking-water sources.

##### **8.4.1 Using data to assess operation and maintenance**

One key element will be to analyse the maintenance of sanitary integrity of the sources and to comment on what implications this may have for overall sustainability of water supply and hygiene interventions. This is a simple analysis looking at the sanitary inspection risk score for water sources. Water supplies with a high risk score have compromised sanitary integrity and indicate weak operation and maintenance. Once an overall risk score exceeds 60%, the supply can be categorised as poorly managed and likely to be contaminated. Therefore, this simple assessment of sanitary integrity can be analysed and commented upon in relation to different water source types.

For point water sources, all the risks included in the sanitary inspection reflect on the operation and maintenance of the water supply. For piped water, measurement of operation and maintenance can focus on certain factors whose presence indicates fundamental weaknesses in operation and maintenance performance. The sanitary inspection forms for treatment works provide an effective

way of assessing operation and maintenance performance during the water production phase. For distribution systems, the supply risks incorporated within a sanitary inspection cover the basic aspects of good sanitary risk management that a water supplier would be expected to control. These include aspects such as signs of leakage, reported pipe bursts, discontinuity within supply and the state of service reservoirs.

The sanitary inspection forms for piped water supply will also typically include local risks that are within the remit of the household or community to control. This covers aspects such as exposure of the household main, water collecting around the base of taps and leaks within the household main. The presence of these risks will indicate whether local operation and maintenance around the facility has been compromised and therefore remedial action and strengthening of local maintenance skills and capacities is required.

A further means of assessing operation and maintenance, and in particular adherence to cleaning and flushing schedules, is to plot chlorine residual levels within the system and in particular to relate these to zones based on service reservoir. Mapping of chlorine residual loss provides information regarding chlorine consumption. Free chlorine loss during distribution indicates that operation and maintenance has been poor and that cleaning and flushing are required or that booster chlorination is needed. A lack of total chlorine may indicate intermittent chlorination.

#### ***8.4.2 Using data to identify the causes of microbial contamination in point sources***

The water quality and sanitary inspection data can be analysed together to evaluate which are likely to be the main controlling factors on microbial contamination. For point sources, analysis can range from relatively simple to complex. However, it should be emphasised that the complexity of analysis will not necessarily mean that the strength of the conclusions are any greater. In some cases simple analysis will provide results in which a high degree of confidence can be placed. In other cases, more complex analysis may be required in order to provide a more accurate reflection of the factors in water quality deterioration. In some cases, only simple analysis is required as there is little variation in water quality (i.e. the sources are consistently significantly contaminated or free of contamination).

Critical to risk factor evaluation is to decide what exactly is being assessed and, in particular, whether an evaluation is made regarding the incidence of contamination above a specified level or severity of contamination found in an open-ended format. These are fundamentally different measures, and different risk factors may be important in different aspects of contamination.

When analysing water quality and sanitary inspection data from the RADWQ survey in addition to the analyses suggested in Section 8.3.2, a simple way to evaluate the impact of particular sanitary risk factors on contamination is to assess the relationship between the presence of each risk factor and a water quality target being exceeded. The most appropriate water quality targets to use are those based on health concerns, such as those in the WHO Guidelines for Drinking-water Quality (WHO, 2011a) or national standards. For utility systems with chlorination, the most appropriate target will be an absence of thermotolerant coliforms and faecal streptococci. For untreated point sources, it may be more appropriate to use a more relaxed target, such as less than 10 TTC/100 ml.

A very simplistic way of analysing these data is to compare the frequency of risk factor reporting when a water quality target is met and when it is exceeded. If the risk factor is more commonly reported as being present when the water quality target is exceeded, this suggests that there is an association between the risk factor and contamination. An example is shown in Table 8.13.

**Table 8.13: Combined sanitary inspection and water quality data analysis for protected springs**

<b>Risk factor</b>	<b>Target met: frequency &lt;10 TTC/100 ml</b>	<b>Target exceeded: frequency ≥10 TTC/100 ml</b>	<b>Difference in frequency</b>
Surface water uphill of spring	45	95	+50
Other pollution uphill	43	84	+41
Eroded backfill	35	58	+23
Diversion ditch absent or faulty	76	95	+19
Masonry faulty	12	26	+14
Flooding of collection area	76	89	+13
Fence absent or faulty	82	95	+13
Animal access within 10m	76	84	+8
Latrine uphill within 30m	4	0	-4

In the example shown in Table 8.13, the frequency analysis suggests that the risk factor “surface water uphill” is more strongly associated with microbial contamination than the risk factor “diversion ditch absent or faulty”, for example. This very simple analysis provides a valuable indication for associations between sanitary risk factors and water quality. However, positive relationships may not be statistically significant. Examples of more advanced statistical analysis are provided in Annex 6.

### **8.4.3 Using data to categorise systems**

By using the water quality analysis and sanitary inspection data, the systems covered by the assessment can be categorised on the basis of contamination found and its most likely cause. For instance, four categories could be used:

- Category 1: No contamination
- Category 2: Contamination derived from local problems
- Category 3: Contamination from both supply failure and local problems
- Category 4: Contamination derived from major supply failure

Such categorisation not only allows attention to be focused on the areas of greatest importance in individual sources or supplies within an urban area, but also allows evaluation of the national situation regarding whether problems exist in design, construction or operation and maintenance. This then allows the development of a regional and/or national improvement strategy (see Section 8.5 and Chapter 9).

### **8.5 Use of data for developing remedial and preventative actions**

In this section, a very brief review will be given about the ways in which the assessment data can be used as a planning tool for remedial and preventative actions. Actions may be undertaken addressing environmental concerns (i.e. control of land-use around sources or reducing pollution discharges), engineering aspects (i.e. design and construction) and educational interventions (i.e. hygiene and maintenance). Possibilities for their use in informing policy choices are further discussed in Chapter 9.

All interventions may be informed by the assessment data and, in particular, when both water quality and sanitary inspection data are collected and analysed together. For any actions to occur it is essential that the data and analysis is reported clearly and concisely and is disseminated (possibly

in a variety of formats) to all relevant stakeholders. This particularly includes local communities participating in the survey, and relevant local or regional authorities. The RADWQ implementation strategy will need to establish communication procedures ensuring that water quality and sanitary inspection findings are reported back in an easy-to-understand format. This will greatly facilitate follow-up remedial actions in response to possible shortcomings. Further details on possible remedial and preventative actions are provided by the WHO Guidelines for Drinking-water Quality (2011a; 1997) and Howard (2002a; 2002b), for example.

### **8.5.1 Environmental interventions**

Environmental interventions will focus primarily on the protection of sources and control of polluting activities within close proximity to the source. The assessment data should provide a good indication of whether current source protection practices are adequate to maintain good quality water. For instance, if the analysis of microbial water quality and sanitary inspection data shows a strong association between latrines or solid waste and contamination, then the current guidance on separation distances or disposal management practices should be reviewed. Many environmental interventions will be closely linked to educational interventions within communities (see Section 8.5.3).

The chemical data will also provide useful indications regarding environmental interventions that are required. For instance, the nitrate levels in source waters may point to increasing contamination from human activity and this should help direct resources to provide greater control on the application of fertilisers and disposal of organic wastes. The use of the pollution risk appraisal forms (examples of which are shown in Annex 2) can also help significantly within this process as these will identify, at least qualitatively, which types of activity are having the greatest impact on water sources.

The water quality assessment data should also be used to help determine whether there are any current problems with naturally occurring chemicals and whether there needs to be a change in resource and source use to reduce these problems. Good examples will include arsenic and fluoride, where evidence of elevated levels in particular areas or from particular aquifers will help inform future development of water resources.

### **8.5.2 Engineering interventions**

There are many engineering interventions that may be developed on the basis of the assessment results. Many of these will be closely linked to educational interventions to improve management (see Section 8.5.3) and environmental interventions at water sources (see Section 8.5.1). Engineering interventions referred to briefly here focus on the design, construction and basic operation and maintenance of water sources, water storage containers and household water treatment.

One key use of the rapid assessment data is to review construction and design quality of water supply technologies. In some cases, it may be clear that these are not of adequate quality, or need revision to improve performance. For example, springs are often protected using very coarse backfill media that provides little potential for filtration and attenuation. If the data from the assessment indicates that springs are heavily contaminated and that this cannot be solely attributed to failures in maintenance, it suggests that the design may need to be revised. This may be particularly important where springs are used in urban areas, which might have greater faecal loading. Improvements in design are often easy to achieve at relatively little additional cost.

Assessment of construction quality is also important. If recently constructed water supplies have significant sanitary risks associated with infrastructure (for instance the masonry or concrete works are failing) this suggests that construction quality is not adequate. This will help in developing new guidelines for construction quality for all organisations and contractors constructing water supplies. The sanitary inspection data will also help in identifying priorities for rehabilitation, in terms of both community and source types.

Where contamination is found, and it appears that it is sanitary completion measures that are the principal cause, then rehabilitation may be justified. Where sources of faecal matter leaching into the sources appear to be most important, then rehabilitation may be less advisable and other technologies selected. Furthermore, if analysis of water quality data show that particular types of source always show heavy contamination and viable alternative types of source exist, then rehabilitation may not be appropriate and other source options should be investigated. By looking at both nitrate and microbial data it may be possible to determine whether groundwater is being affected by on-site sanitation or some other form of organic material, which may suggest that rehabilitation is not advisable.

The sanitary inspection data from piped water systems can help in directing remedial actions. This may be from the sanitary inspection data or from mapping of chlorine residuals. The identification of major supply risks should lead to investment or improved operation and maintenance practices to address these problems. Where the sanitary inspection data suggest that problems largely result from poor local operation and maintenance, this should lead to action to improve management by households and communities or utility operators, respectively.

The assessment data should inform operation and maintenance needs. Through assessing the water quality and sanitary inspection data, critical maintenance tasks can be identified to ensure continued good water quality. This can then be used to develop better community and/or operator's training for sustainable management of water supplies.

The assessment data can also be used to evaluate the current performance of water storage containers and point of use treatment technologies employed at the household level. This should allow identification of the designs that provide greatest protection to water and which provide the treatment of water. This may be done by looking at those specific factors that are most associated with contamination and designing new containers and devices to reduce these risks.

### ***8.5.3 Educational interventions***

Educational interventions may be needed for improving both source maintenance and hygiene promotion. In both cases, the use of water testing equipment and sanitary inspections as direct learning tools should be emphasised. By directly involving communities in these activities on-site, for instance by reading the results of water quality tests with the community, there is greater potential for sustainable improvements to be developed. Also, on the occasion of the visits, field teams may provide on-site advice to community members in response to shortcomings identified during sanitary inspection or distribute pre-prepared education materials (i.e. on household hygiene, hand washing practices or safe storage and handling of water in home). This learning approach should explicitly be built-in into the RADWQ implementation strategy, if possible.

Where the sanitary inspection risk score at sources is high, this provides a good indication that design, construction, operation and/or maintenance is poor and that there needs to be strengthening of local capacity to improve management. The sanitary inspection data should provide a good indication of specific practices that are failing, but further discussions with communities are likely to be required to understand the underlying reasons for failures.

One area that the assessment can help to inform is whether household water treatment or hygiene education will be most useful in addressing problems of poor water quality in the home. If hygiene education interventions will be able to provide a safe water chain from the source to the household then there may be no need for household water treatment.

Where the water quality at the source is relatively good but the water stored within households is poor, this suggests that hygiene education alone may be able to resolve water contamination. Where these situations are found then the sanitary inspection data should be analysed to assess what particular factors seem to be most associated with re-contamination, for instance design or type of container, or means of taking water from the container. By identifying the critical sanitary risk factors, the hygiene education programme can develop specific messages aimed at improving water handling hygiene.

Where the water source itself is heavily contaminated and there is little possibility of improving the source, it may be necessary to promote low-cost household water treatment. If this is followed then it is important to consider carefully what type of technology may be most appropriate and how this will be promoted most effectively. Generally, promoting boiling of water is rarely sustainable for long periods of time, as it is expensive, produces water with a poor taste and which must be cooled, and may lead to deforestation and air pollution. It is better not to regularly promote messages regarding boiling of water, but to leave these until times of greatly increased risk (for instance during an epidemic or mass contamination of water). Alternative technologies such as solar disinfection and/or use of simple, locally made (ceramic) filtration devices may be more appropriate.

If household water treatment products and systems are promoted, it is important to be sure that households can purchase these easily and cheaply, and that any consumables can be easily purchased close to or preferably within their community. Selecting appropriate promotional methods is important, and social marketing is often an important component of this. Water quality and sanitary inspection data can be useful, as they can provide the evidence of the performance of the treatment system and be used to promote the use of the treatment technology. Further information on household water treatment options and technology selection criteria can be found in WHO (2011b) and Sobsey (2002), for example.

## **9 USING FINDINGS FROM RAPID ASSESSMENTS OF DRINKING-WATER QUALITY TO INFORM POLICY CHOICES**

The findings of rapid assessments of drinking-water quality can be used to inform policy choices about water supplies, water quality and water quality surveillance, to help identify priorities and direct future investments. The rapid assessment data should provide robust, defensible results that demonstrate the scientific basis in setting out the range of policy options and identifying the preferred approach. Scientific evidence is a critical component of the policy-making process and should be used to inform debate and the financial and political decision-making process by giving clear indications of current conditions and the potential scale of particular problems.

There is increasing demand for evidence-based policy, although too often policies still get set on the basis of inadequate information and poor to non-existent evidence. This is particularly the case in low-income countries where evidence is often absent, patchy or of poor quality. However, although important, the results of a rapid water quality assessment will only be one component in the policy-making process; there will be social, financial, technical and political aspects that will need to be considered, and these will influence recommendations based on the results of a rapid assessment.

For the results to inform policy choices effectively, they must be presented in formats that are comprehensible for policy makers and for the general public to aid consultation. This means that simple terms and clear messages about key findings and about the limits of uncertainty must be given; also, the findings must be presented in relation to a broader context and other existing information about water quality. If policy makers cannot understand the information they are being presented with, because it is done in a way that requires specialist knowledge, then they may disregard it. To increase the potential for rapid assessment data to lead to policy changes, those data require thorough analysis (see also Chapter 8) and integration with other relevant and complementary data.

There are a number of policy interventions that can be informed by the rapid assessment results. These include:

- national overview of water quality indicators of concern;
- evidence base to establish national water quality standards;
- contextualising the results for policy makers; and
- identification of specific water quality mitigation options.

### **9.1 National overview**

The results of the rapid assessment aid the provision of an evidence base for the identification of key water quality indicators and parameters of concern, particularly in those countries or regions where planned and routine water quality monitoring and surveillance is undertaken infrequently, in urban areas only, or not at all. For example, in the RADWQ pilots in Nicaragua, the government stated that the primary strength of the RADWQ assessment was to enlighten government officials of the extent of contamination of water quality in the country. Furthermore, the rapid assessments also helped to emphasise the widespread level of microbial contamination. The presence of microbial contamination and its known linkage with diarrhoeal diseases helps to advocate to governments for the establishment of water quality policies. A rapid assessment may also identify specific chemicals of national or regional concern (such as arsenic, fluoride or nitrate) and contribute to the development of specific policies related to their monitoring, surveillance and mitigation, including interventions in water supply, health, agriculture and water resources.



## **9.2 Water quality standards**

Evidence from the rapid assessment can provide a baseline for the establishment or revision of national water quality standards. Where standards exist they can be reviewed in light of the analysis of rapid assessment data with potential revisions including, for example, the range of water quality parameters of key concern. As an example, Nigeria, one of the RADWQ pilot countries, reported that it intends to use the RADWQ data to review their national standards.

In many countries, sanitary inspection is not an integral component of the national standard. Once the rapid assessment has been undertaken, the value of such inspections as an essential component of water quality assessment may become clear to national governments and lead to the inclusion of sanitary inspections in the national standards. Furthermore, rapid assessment findings will contribute to the evidence base for assessing whether different approaches for monitoring, surveillance and control of water quality need to be taken in rural and urban water supplies.

## **9.3 Contextualising the results for policy makers**

To maximise the influence of the results of the rapid assessment, it is important to try to provide a broader context or to give interpretations of what the results mean in, for example, public health or financial terms. For instance, relating levels of contamination to a likely public health burden is an important way of provide policy makers with the kind of evidence that is more understandable and relevant to their needs. This can be done through using the data to model what the impacts may be on a population, within clearly described limits of uncertainty. For example, in Bangladesh a quantitative health risk tool was developed that used water quality results as an input to estimate likely disease burdens associated with particular technologies and levels of contamination for both arsenic and pathogens (see Ahmed *et al.*, 2006; Howard *et al.*, 2007).

There may be limits to the number of contaminants for which this health risk can be estimated and to what degree of certainty. Using the approach described in this handbook, it is likely that at best what can be determined for pathogens will be a qualitative ranking of technologies in relation to disease burden and order of magnitude estimates of likely disease burden (Howard *et al.*, 2007). This is in part because of some of the inherent difficulties in defining the relationship between indicator organisms and pathogens. Other situations, e.g. when pathogens are monitored and large amounts of routine monitoring data are available, will allow more quantitative estimates and reduce (but not eliminate) the uncertainty to a significant degree.

For chemical contaminants the results of a rapid assessment (particularly if laboratory methods are used for parameters having a health risk at very low concentrations), can lead to much closer estimates of disease burden where dose-response relationships are reasonably well understood, for instance as is the case for arsenic and fluoride. For other chemicals, the limitations on dose-response relationships will limit the degree of certainty about the disease burden estimates.

The advantage of translating water quality results into public health concern is that this provides much more meaningful data for policy makers to make decisions about the level of health protection required from water supply. This should take into account other environmental health burdens and the relative costs and public health gain from improved water quality compared to those associated with other interventions (e.g. health and hygiene promotion). The policy process that results from this information should provide clear directions for investment priorities in water and sanitation and lead to programmes of support by governments and partners in addressing key public health problems.

Policy choices with regard to water quality standards may also be set without considering other environmental health risks, and the results of a rapid assessment data can feed into this process. By

stating clearly the current level of contamination for particular substances, estimations can be made of the costs of setting standards, or decisions made on what the guidelines should be. For instance, if large numbers of improved water supply technologies showed contamination, and in some cases very high levels for a particular indicator/parameter, comparisons can be made to estimate the cost and the health burdens with meeting either the WHO guideline value or a less stringent national standard. This can allow policy-makers to determine whether it is reasonable to stick with the higher national standard and ensure that all water supplies meet this target or whether adoption of a lower, more stringent standard is realistic and/or whether movement to the lower WHO guideline value should be phased to allow for necessary investments in mitigation to be made. In this situation, the additional costs for achieving the lower standard or WHO guideline value need to be related to the associated change to the health burden.

#### **9.4 Identification of specific water quality mitigation options**

The findings of a rapid assessment may also support policy interventions through source protection, water treatment requirements or technology upgrades. Examples may include the need to provide covers and hand pumps on dug wells, new wellhead protection areas or protection zones around mechanised boreholes, treatment for fluoride contaminated groundwater, the use of alternative technologies in arsenic affected areas and the requirement for chlorination in highly vulnerable water supplies. An example of this is outlined in Box 9.1.

<b>Box 9.1: Response plans to RADWQ in India</b>
RADWQ was implemented in the Central Indian State of Madhya Pradesh. A total of 6,400 samples were collected, and of these, 2,000 samples were microbially contaminated and water sources had a very high level of sanitary risk. To respond to the problem, the Public Health Engineering Department and UNICEF analysed the RADWQ data to see which sanitary risks were most prominent and in which areas of the State. Common sanitary risks included cracked platforms and the presence of animals within 10 metres of the hand pumps. The Public Health Engineering Department then financed the fixing of cracked platforms in all 2,000 wells. Afterwards, a smaller scale RADWQ was repeated by the Department to validate the improvement.

Additionally, it should be possible to use the results of a rapid assessment to identify which technologies provide the greatest public health protection and the recommended solutions within an overall context of a demand-responsive approach to water supply provision. Such decisions may be considered a form of health-based target (WHO, 2011a). An example of this approach is the use of rapid assessment findings in Bangladesh, which are outlined in Box 9.2.

<b>Box 9.2: RADWQ for technology selection in Bangladesh</b>
In Bangladesh, a RADWQ study was designed to answer a specific policy question related to the preference accorded to different technologies used for arsenic mitigation. This was in the context of an existing policy position that had set out a hierarchy of technologies for use that was not based on scientific evidence. The rapid assessment was designed to provide an answer to the key questions of what disease burden was associated with each technology option (risk substitution) and which technologies should be considered as preferred in arsenic mitigation. The result of the assessment was that one technology (i.e. deep tubewells) had a much lower disease burden than other options and should be considered as the preferred option from a public health perspective wherever feasible. It was concluded that other technologies could be used, but would require significant improvements in design and, in the case of two technologies, should have an additional treatment step (i.e. chlorination) as standard.

In other settings, the results of a rapid assessment may indicate a policy change in terms of acceptable levels of treatment. For instance, if the results show an elevated risk from microbial contamination in certain seasons, a policy may be developed requiring that disinfection be included in the design. If the environmental surveys indicate that there are elevated risks either from pathogens (e.g. for instance *Cryptosporidium*) or from pesticides, then development of policies requiring adequate treatment to be installed may be necessary.

### ***9.5 Using rapid assessment data in other policy decisions***

The rapid assessment data may also drive policy decisions in other aspects of water supply that were not under direct study within a rapid assessment. For instance, identifying the level of contamination of non-piped water supplies in urban areas as being of an unacceptable quality may lead to changes in tariffs for utility supplies that allow poor people greater access to treated piped supplies. In order to achieve such a policy direction, work will have to be done to demonstrate the difference in quality between the piped and other supplies, make defensible predictions about the consequent disease burden, and be able to show that increased use of the utility supply is feasible both physically and financially. Thus the rapid assessment data must be integrated with other relevant and complementary data, and may lead to further data requirements being identified before a policy decision is reached.

In countries where planned and systematic approaches to water quality monitoring and surveillance are either absent or scarcely enforced, rapid assessments can provide statistically representative data on drinking-water quality and sanitary conditions. Such data, as well as the practical experiences in implementing RADWQ, can be used as “springboard” information for policy makers. They can underpin the need for developing a well-planned and cost-effective approach to routine monitoring and surveillance, particularly as a means to monitor long-term improvements in drinking-water quality. In turn, rapid assessment data can be used to establish an information basis for planning and implementing result-oriented interventions (e.g. for increasing access to “improved” water supplies through construction and rehabilitation programmes or for developing water-related hygiene education programmes). The RADWQ will inform decisions on the design and priorities of routine monitoring and surveillance programmes, particularly with respect to water quality parameters and supply technologies to be included in such programmes as well as technical and personnel resources required (including capacity building needs). Ethiopia, one of the RADWQ pilot countries, expressed the intention to use the results of the study as the basis for developing a systematic and long-term approach to national water quality monitoring and surveillance.

## **ANNEXES**

Annex 1:	Bibliography .....
Annex 2:	Sanitary inspection and rapid environmental risk assessment forms .....
Annex 3:	Quality control procedures .....
Annex 4:	Field data daily reporting form.....
Annex 5:	Example checklists for preparation of field work .....
Annex 6:	Options for advanced statistical analysis.....
Annex 7:	Suggested final report structure.....

## Annex 1

---

### Bibliography

- Ahmed F, Howard G, Deere D, Mahmud SG, Shamsuddin A (2006). Quantitative health risk assessment for arsenic and microbial contamination of drinking-water. Arsenic Policy Support Unit (APSU), Dhaka.
- Bartram J, Ballance R (Eds.) (1996). Water quality monitoring. E&FN Spon, London. Available at [http://www.who.int/entity/water\\_sanitation\\_health/resourcesquality/waterqualmonitor.pdf](http://www.who.int/entity/water_sanitation_health/resourcesquality/waterqualmonitor.pdf) (accessed 11 June 2012).
- Bartram J, Corrales L, Davison A, Deere D, Drury D, Gordon B, Howard G, Rinehold A, Stevens M (2009). Water safety plan manual: step-by-step risk management for drinking-water suppliers. World Health Organization, Geneva. Available at [http://whqlibdoc.who.int/publications/2009/9789241562638\\_eng.pdf](http://whqlibdoc.who.int/publications/2009/9789241562638_eng.pdf) (accessed 30 May 2012).
- Dufour A, Bartram J, Bos R, Gannon V (Eds.) (2012). Animal waste, water quality and human health. International Water Association, London, World Health Organization, London, Geneva. Available at: [http://www.who.int/water\\_sanitation\\_health/publications/2012/animal\\_waste/en/index.html](http://www.who.int/water_sanitation_health/publications/2012/animal_waste/en/index.html) (accessed 18 October 2012).
- Fawell J, Bailey K, Chilton J, Dahi E, Fewtrell L, Magara Y (2006). Fluoride in drinking-water. World Health Organization, Geneva. Available at [http://www.who.int/entity/water\\_sanitation\\_health/publications/fluoride\\_drinking\\_water\\_full.pdf](http://www.who.int/entity/water_sanitation_health/publications/fluoride_drinking_water_full.pdf) (accessed 11 June 2012).
- Helsel DR, Hirsch RM (1992). Statistical methods in water resources. Elsevier Science, Amsterdam. Available at <http://www.practicalstats.com/aes/aesbook/files/HelselHirsch.PDF> (accessed 11 June 2012).
- Howard G (2002a). Water supply surveillance: a reference manual. Water, Engineering and Development Centre (WEDC), Loughborough University.
- Howard G (2002b). Water quality surveillance: a practical guide. Water, Engineering and Development Centre (WEDC), Loughborough University.
- Howard G, Pedley S, Barrett M, Nalubega M and Johal K (2003). Risk factors contributing to microbial contamination of shallow groundwater in Kampala, Uganda. *Water Research* 37 (14): 3421-3429.
- Howard G, Ahmed MF, Shamsuddin AJ, Mahmud SG, Deere D (2006a). Risk assessment of arsenic mitigation options in Bangladesh. *Journal of Health, Population and Nutrition* 24 (3): 346-355.
- Howard G, Godfrey S, Boonyakarnkul T (2006b). Sanitary completion of protection works around of groundwater sources. In: Schmoll O, Howard G, Chilton J, Chorus I: Protecting groundwater for health: managing the quality of drinking-water sources. World Health Organization, Geneva. Available at [www.who.int/water\\_sanitation\\_health/publications/protecting\\_groundwater/en/index.html](http://www.who.int/water_sanitation_health/publications/protecting_groundwater/en/index.html) (accessed 11 June 2012).
- Howard G, Ahmed MF, Teunis P, Mahmud SG, Davison A, Deere D (2007). Disease burden estimation to support policy decision-making and research prioritisation for arsenic mitigation. *Journal of Water and Health*, 5 (1): 67-81.
- Hunter PR, Zmirou-Navier D, Hartemann P (2009). Estimating the impact on health of poor reliability of drinking-water interventions in developing countries. *Science of the Total Environment*, 407 (8): 2621-2624.

- Ince M, Bashir D, Oni OOO, Awe EO, Ogbechie V, Korve K, Adeyinka MA, Olufolabo AA, Ofordu F, Kehinde M (2010). Rapid assessment of drinking-water quality in the Federal Republic of Nigeria: country report of the pilot project implementation in 2004-2005. World Health Organization, Geneva, United Nations Children's Fund, New York. Available at [http://www.wssinfo.org/fileadmin/user\\_upload/resources/RADWQ\\_Nigeria.pdf](http://www.wssinfo.org/fileadmin/user_upload/resources/RADWQ_Nigeria.pdf) (accessed 31 May 2012).
- Lloyd B, Helmer R (1991). Surveillance of drinking-water quality in rural areas. Published on behalf of the World Health Organization and the United Nations Environment Programme by Longman House, Harlow.
- Sobsey M (2002). Managing win the home: accelerated health gains from improved water supply. World Health Organization, Geneva. Available at [http://www.who.int/water\\_sanitation\\_health/dwq/WSH02.07.pdf](http://www.who.int/water_sanitation_health/dwq/WSH02.07.pdf) (accessed 2 June 2012).
- Tadesse D, Desta A, Geyid A, Girma W, Fisseha S, Schmoll O (2010). Rapid assessment of drinking-water quality in the Federal Republic of Ethiopia: country report of the pilot project implementation in 2004-2005. World Health Organization, Geneva, United Nations Children's Fund, New York. Available at [http://www.wssinfo.org/fileadmin/user\\_upload/resources/RADWQ\\_Ethiopia.pdf](http://www.wssinfo.org/fileadmin/user_upload/resources/RADWQ_Ethiopia.pdf) (accessed 31 May 2012).
- Thompson T, Fawell J, Kunikane S, Jackson D, Appleyard S, Callan P, Bartram J, Kingston P (2007). Chemical safety of drinking-water: assessing priorities for risk management. World Health Organization, Geneva. Available at [http://whqlibdoc.who.int/publications/2007/9789241546768\\_eng.pdf](http://whqlibdoc.who.int/publications/2007/9789241546768_eng.pdf) (accessed 30 May 2012).
- UNICEF (1995). Monitoring progress toward the goals of the world summit for children: a practical handbook for multiple-indicator surveys. United Nations Children's Fund, New York.
- UNICEF (2006). Multiple indicator cluster survey manual 2005: Monitoring the situation of children and woman. United Nations Children's Fund, New York. Available at [http://www.childinfo.org/files/Multiple\\_Indicator\\_Cluster\\_Survey\\_Manual\\_2005.pdf](http://www.childinfo.org/files/Multiple_Indicator_Cluster_Survey_Manual_2005.pdf) (accessed 11 June 2012).
- UNICEF (2008). UNICEF handbook on water quality. United Nations Children's Fund, New York. Available at [http://www.unicef.org/wash/files/WQ\\_Handbook\\_final\\_signed\\_16\\_April\\_2008.pdf](http://www.unicef.org/wash/files/WQ_Handbook_final_signed_16_April_2008.pdf) (accessed 30 May 2012).
- USEPA (1999). Guidance manual for conducting sanitary surveys of public water systems; surface water and groundwater under the direct influence. United States Environmental Protection Agency, Washington. Available at [www.epa.gov/ogwdw/mdbp/pdf/sansurv/sansurv.pdf](http://www.epa.gov/ogwdw/mdbp/pdf/sansurv/sansurv.pdf) (accessed 2 June 2012).
- WHO (1997). Guidelines for drinking-water quality, volume 3: surveillance and control of community water supplies, 2<sup>nd</sup> edition. World Health Organization, Geneva. Available at [http://www.who.int/entity/water\\_sanitation\\_health/dwq/gdwqvol32ed.pdf](http://www.who.int/entity/water_sanitation_health/dwq/gdwqvol32ed.pdf) (accessed 30 May 2012).
- WHO (2011a). Guidelines for drinking-water quality, 4<sup>th</sup> edition. World Health Organization, Geneva. Available at [http://whqlibdoc.who.int/publications/2011/9789241548151\\_eng.pdf](http://whqlibdoc.who.int/publications/2011/9789241548151_eng.pdf) (accessed 30 May 2012).
- WHO (2011b). Evaluating household water treatment options: Health-based targets and microbial performance specifications. World Health Organization, Geneva. Available at [http://www.who.int/water\\_sanitation\\_health/publications/2011/evaluating\\_water\\_treatment.pdf](http://www.who.int/water_sanitation_health/publications/2011/evaluating_water_treatment.pdf) (accessed 2 June 2012).

WHO (2012). Water safety planning for small community water supplies: Step-by-step risk management guidance for drinking-water supplies in small communities. World Health Organization, Geneva. Available at [http://www.who.int/water\\_sanitation\\_health/publications/2012/water\\_supplies/en/index.html](http://www.who.int/water_sanitation_health/publications/2012/water_supplies/en/index.html) (accessed 18 October 2012).

UNICEF, WHO (2012). Progress on sanitation and drinking-water: 2012 update. United Nations Children's Fund, New York, World Health Organization, Geneva. Available at [http://whqlibdoc.who.int/publications/2012/9789280646320\\_eng\\_full\\_text.pdf](http://whqlibdoc.who.int/publications/2012/9789280646320_eng_full_text.pdf) (accessed 30 May 2012).

## **Annex 2**

---

### **Sanitary inspection and rapid environmental risk assessment forms**

- **Sanitary inspection forms and explanatory notes**

  - Generic

  - Piped water: Treatment process

  - Piped water: Distribution system

  - Household container

  - Household piped water

  - Protected spring

  - Borehole with mechanised pumping

  - Borehole with hand pump

  - Dug well with hand pump

  - Rainwater harvesting tank

- **Rapid environmental risk assessment form**



RADWQ SANITARY INSPECTION FORM  
GENERIC

---

**I. General information (a-c essential, d-f optional)**

- a. WSS No.: *Contains information on location, cluster and technology.*
- b. Village/Town: *For easy visual reference and use in future planning.*
- c. Date of visit: *Check on seasonality and for use in linking data sets.*
- d. Broad area/Region: *As a check and for easy visual reference as encoded in WSS No.*
- e. Zone: *As a check and for easy visual reference as encoded in WSS No.*
- f. People served: *Of use to update records and in planning future supply provision.*

*Note: Additional technology or survey-specific question(s) can be covered in section III of the form.*

**II. Specific diagnostic information for assessment:**

*For RADWQ each technology has 10 questions relating to risk to water quality. The questions relate to:*

- *Identification of specific causes of known contamination (e.g. animal access);*
- *Identification and evaluation of factors likely to affect the long-term risk of contamination (insanitary conditions or practices at the source); and*
- *Assistance with monitoring and evaluation of operation and maintenance activities for water supplies (e.g. cracks/breaks in structures).*

*The questions are structured so that a 'Yes' answer indicates that there is a potential risk and a 'No' answer that there is no/very low risk. For example:*

- |  |             |
|--|-------------|
|  | <b>Risk</b> |
| 1. Is there a latrine within 10 m of the well? | Y/N         |

*A 'Yes' answer indicates the potential for faecal pollution of the source through e.g. run-off or infiltration, which constitutes a risk to water quality. A 'No' answer indicates that no risk has been identified by this question.*

*Once all 10 questions have been answered at the site, the total of 'Yes answers' (= x) is entered, giving the total score of risks (= x/10). This score is then entered in the appropriate column in table in section III below, which identifies the risk category.*

**III. Results and comments:**

- a. Sanitary inspection risk score (tick appropriate box):

9-10 = Very high	6-8 = High	3-5 = Medium	0-2 = Low

- b. The following important points of risk were noted:

- List nos. 1-10
- Additional comments (continue on back of form if necessary)

- c. *There may be technology-specific questions that need to be answered. E.g. for dug wells an important question is 'Indicate if the dug well is not protected'. This would allow for correction of inaccuracies in recording of technologies.*

**IV. Name and signature of assessors:**

*This allows for cross-checking if there are any queries when analysing data and may identify additional training requirements.*

**RADWQ SANITARY INSPECTION FORM**  
**PIPED WATER: TREATMENT PROCESSES**

---

**I. General information:**

- a. WSS No.: .....
- b. Village/Town: .....
- c. Date of visit: .....
- d. Treatment processes used: .....
- e. Broad area/Region: .....
- f. Zone: .....
- g. People served: .....

**II. Specific diagnostic information for assessment:**

(Please indicate at which sites the risk was identified)

**Risk**

- 1. Are there evident hydraulic surges at the intake? Y/N
- 2. Are there evident cracks in the pre filters? Y/N
- 3. Are there leaks in the mixing tank? Y/N
- 4. Is the mixing tank in an insanitary condition? Y/N
- 5. Is there evidence of insufficient coagulant dosing (e.g. alum)? Y/N
- 6. Is any sedimentation tank in an insanitary condition? Y/N
- 7. Are there mud balls or cracks in any of the filters? Y/N
- 8. Is the air and water supply distribution in any sand bed uneven? Y/N
- 9. Are there evident cross connections between backwashed and treated water? Y/N
- 10. Are free residual chlorine concentrations (minimum 0.2 mg/l) not being achieved? Y/N

**Total score of risks: ...../10**

**III Results and comments:**

a. Sanitary inspection risk score (tick appropriate box):

9-10 = Very high	6-8 = High	3-5 = Medium	0-2 = Low

b. The following important points of risk were noted:

- List nos. 1-10
- Additional comments (continue on back of form if necessary)

**IV Name and signature of assessors:**

**EXPLANATORY NOTES**  
**PIPED WATER: TREATMENT PROCESSES**

---

**1. Are there evident hydraulic surges at the intake?**

Treatment stages are designed to operate on fairly steady flows, so any sudden changes in flow may reduce the effectiveness of treatment stages, such as chemical dosing, sedimentation and filtration. If there are evident hydraulic surges at the intake, answer 'Yes'.

**2. Are there evident cracks in the pre filters?**

Deep cracks (not surface cracks) in the walls could allow contamination to enter the pre filters, affecting the quality of the water to be treated and also allow water to by-pass the medium in the pre filters. In addition, cracks in either the pre filter walls or the filter medium, suggest that operating and maintenance procedures are poor, implying that there may be weaknesses in the treatment process. If there are cracks in either the pre filter walls, or in the filter medium, answer 'Yes'.

**3. Are there leaks in the mixing tank?**

If the tank is leaking this may provide a route for contaminants to enter the pipes as well as a route for chemicals to leak out of the tank. This could affect the chemical dosing, so that chemicals are wasted and chemical doses are different from those intended. As for question 1, leakage in the mixing tank suggests that operating and maintenance procedures are poor, implying that there may be weaknesses in the treatment process. If there are leaks in the mixing tank, answer 'Yes'.

**4. Is the mixing tank in an insanitary condition?**

Insanitary conditions, such as biological growths or accumulation of sediments, suggests that dead or living microorganisms, or their wastes, may be entering the flow, affecting the quality of the water to be treated. Treatment facilities may have been planned for a water of better raw water quality. Insanitary conditions in the mixing tank suggest that operating and maintenance procedures are poor, implying that there may be weaknesses in the treatment process. If the mixing tank is in an insanitary condition, answer 'Yes'.

**5. Is there evidence of insufficient coagulant dosing (e.g. alum)?**

Use of an insufficient dose of coagulant will not encourage formation of large flocs and removal of a high percentage of suspended solids, leaving suspended solids that may not be removed by subsequent treatment stages. The presence of small suspended solids in the flow out of sedimentation tanks, or in the flow out of filters, provides visible evidence of insufficient coagulant dosing. Pathogenic bacteria may be attached to suspended solids, and may therefore pass through treatment stages if insufficient coagulants are used. If evidence suggests that the coagulant dosing is insufficient, answer 'Yes'.

**6. Is any sedimentation tank in an insanitary condition?**

Insanitary conditions, such as biological growths or accumulation of sediments, suggests that dead or living microorganisms, or their wastes, may be entering the flow, affecting the quality of the water leaving the sedimentation tank, and possibly overloading subsequent treatment stages. Treatment facilities may have been planned for a water of better raw water quality. Insanitary conditions in a sedimentation tank suggest that operating and maintenance procedures are poor, implying that there may be weaknesses in the treatment process. If sedimentation tanks are in an insanitary condition, answer 'Yes'.

**7. Are there mud balls or cracks in any of the filters?**

The presence of mud balls (clusters of sand cemented together, formed where dirt has collected) or cracks in the filter bed provide visible evidence of uneven flows through the filter. Filtration will not occur in mud-balls, and flows will be concentrated in other parts of the filter, where overloading and incomplete treatment may occur. Where there are visible cracks in the filter surface, water will flow through these cracks, without being filtered and with no improvement in quality. Both

conditions (mud balls or cracks) reduce the effectiveness of filters, so that pathogens may not be removed in the filter bed. If there are mud balls or cracks in any of the filters, answer 'Yes'.

**8. Is the air and water supply distribution in any sand bed uneven?**

If distribution of the air and water, used for backwashing (cleaning) rapid gravity filters, is not even, some areas of the filter will not be cleaned effectively and filtration will also be uneven and incomplete. Partially blocking of some parts of the filter by accumulated dirt will mean that other parts are overloaded and pathogens may not be fully removed in the filter bed. If the supply of air and water used for backwashing filters is distributed unevenly across a filter, answer 'Yes'.

**9. Are there evident cross connections between backwashed and treated water?**

The volume of water used for backwashing is much less than the volume of water that is filtered, and the impurities are therefore concentrated in the backwash water, which usually removes impurities from the top of a filter. Any cross connection between backwashed and treated water risks be re-contamination of the treated water by the impurities (including pathogens) present in the backwash water. If there is evidence of cross connections between backwashed water and treated water, answer 'Yes'.

**10. Are free residual chlorine concentrations (minimum 0.2 mg/l) not being achieved?**

Water in distribution may not stay pathogen-free if free residual chlorine concentrations are <0.2 mg/l. You will need to check recent records at the treatment plant (laboratory where samples are tested or data are stored). These should also be compared with the chlorine values found in water samples collected at the time of the inspection. If the chlorine levels are not being achieved, answer 'Yes'.

**RADWQ SANITARY INSPECTION FORM**  
**PIPED WATER: DISTRIBUTION SYSTEM**

---

**I. General information:**

- a. WSS No.: .....
- b. Village/Town: .....
- c. Date of visit: .....
- d. Broad area/Region: .....
- e. Zone: .....

**II. Specific diagnostic information for assessment:**

(Please indicate at which sites the risk was identified)

**Risk**

- 1. Do any taps or pipes leak at the sample site? Y/N
- 2. Does water collect around the sample site? Y/N
- 3. Is the area around the tap insanitary? Y/N
- 4. Is there a sewer or latrine within 30 m of any tap? Y/N
- 5. Has there been discontinuity in the last 10 days? Y/N
- 6. Is the supply main pipeline exposed in the sampling area? Y/N
- 7. Do users report any pipe breaks within the last week? Y/N
- 8. Is the supply tank cracked or leaking? Y/N
- 9. Are the vents on the tank damaged or open? Y/N
- 10. Is the inspection cover or concrete around the cover damaged or corroded? Y/N

**Total score of risks: ...../10**

*Explanatory note: Questions 1-7: Taps refers to inspection taps or public taps (where directly connected to distribution system). Questions 8-10: A supply tank is either a clean water/storage tank at the water treatment works or in the distribution system.*

**III Results and comments:**

- a. Sanitary inspection risk score (tick appropriate box):

9-10 = Very high	6-8 = High	3-5 = Medium	0-2 = Low

- b. The following important points of risk were noted:
  - List nos. 1-10
  - Additional comments (continue on back of form if necessary)

**IV Name and signature of assessors:**

**EXPLANATORY NOTES**  
**PIPED WATER: DISTRIBUTION SYSTEM**

---

**1. Do any taps or pipes leak at the sample site?**

If taps are leaking or pipes are damaged then cracks may provide a route for contaminants to enter the pipes. You will need to differentiate between water from leaking taps and spilt water. If you observe leaks or damage at taps then answer 'Yes'.

**2. Does water collect around the sample site?**

If pools of water collect around the sampling site they may provide a route for contaminants to enter the distribution system. If you observe spilt water or pools of water close to the sampling site then answer 'Yes'.

**3. Is the area around the tap insanitary?**

Faeces, garbage and other wastes pose a risk to the water quality. If you see these close to the tap, answer 'Yes'.

**4. Is there a sewer or latrine within 30 m of any tap?**

Any leaks from the sewer or infiltration from the latrine could contaminate the piped water (especially if there are any cracks in the distribution system). You can observe latrines and cross-check with residents but you may need to ask relevant professionals about the location of sewers. If either a sewer or latrine is present then answer 'Yes'.

**5. Has there been discontinuity in the last 10 days?**

During discontinuities the distribution pipes become empty and pressure differences may lead to ingress of water (and silt) from the soil around the pipes. The soil may be contaminated posing a risk to water quality. You will need to ask residents about discontinuities (record the frequency and duration if this is possible). If there has been a discontinuity then answer 'Yes'.

**6. Is the supply main pipeline exposed in the sampling area?**

Exposure of the pipe means that it is more prone to both damage (especially if by/on a road) and contamination from run-off etc. You will need to identify the route of the main pipeline near to the sampling site. If the pipeline is exposed, answer 'Yes'.

**7. Do users report any pipe breaks within the last week?**

Pipe breaks (or major leaks) pose a risk to water quality as contaminants can enter the system through the break. You will need to ask residents about any pipe breaks. You could also check on whether the system was disinfected after the break was mended. If breaks are reported, answer 'Yes'.

**8. Is the supply tank cracked or leaking?**

Cracks allow contaminants to reach the water stored in the tank. If deep cracks that penetrate the tank (i.e. not just superficial ones) are found then answer 'Yes'.

**9. Are the vents on the tank damaged or open?**

Damaged or open vents allow contaminants to reach the water stored in the tank. If these are observed, answer 'Yes'.

**10. Is the inspection cover or concrete around the cover damaged or corroded?**

Damaged (or absent) covers and cracked concrete surrounds allow contaminants to reach the water stored in the tank. If either of these is observed, answer 'Yes'.

**RADWQ SANITARY INSPECTION FORM**  
**HOUSEHOLD CONTAINER**

---

**I. General information:**

- a. WSS No.: .....
- b. WSS No. of source related to household sample: .....
- c. Village/Town: .....
- d. Date of visit: .....
- e. Broad area/Region: .....
- f. Zone: .....

**II. Specific diagnostic information for assessment:**

(Please indicate at which sites the risk was identified)

**Risk**

- 1. Is the water storage container used for storing any other liquid or material? Y/N
- 2. Is the water storage container kept at ground level? Y/N
- 3. Is the water storage container lid or cover absent or not in place? Y/N
- 4. Is the storage container cracked, leaking or insanitary? Y/N
- 5. Is the area around the storage container insanitary? Y/N
- 6. Do any animals have access to the area around the storage container? Y/N
- 7. Is the tap or utensil used to draw water from the container insanitary? Y/N
- 8. Is the water from the container also used for washing or bathing? Y/N
- 9. Has there been discontinuity in water supply in the last 10 days? Y/N
- 10. Is the water obtained from more than one source? Y/N

**Total score of risks: ...../10**

**III Results and comments:**

a. Sanitary inspection risk score (tick appropriate box):

9-10 = Very high	6-8 = High	3-5 = Medium	0-2 = Low

- b. The following important points of risk were noted:
  - List nos. 1-10
  - Additional comments (continue on back of form if necessary)

**IV Name and signature of assessors:**

## EXPLANATORY NOTES HOUSEHOLD CONTAINER

---

**1. Is the water storage container used for storing any other liquid or material?**

Other liquids or materials in contact with the container may be contaminated and thus constituting a risk to water quality. You will need to check the container visually for evidence of this practice and also ask the residents. If this is the situation, answer ‘Yes’.

**2. Is the water storage container kept at ground level?**

Storage at ground level constitutes a risk to water quality, especially when environmental sanitation practices are poor. You can check visually the location of the container. If this is the case, answer ‘Yes’.

**3. Is the water storage container lid or cover absent or not in place**

Water stored in uncovered containers can be easily contaminated. You can check visually for the lid or cover (and also ask residents). If the lid or cover is absent or not in place, answer ‘Yes’.

**4. Is the storage container cracked, leaking or insanitary?**

Cracks in a damaged container may provide an entry route for contaminants. You will need to differentiate between water from leaking from the container and spilt water. If the container is insanitary it poses a risk to water quality. If the container is damaged, leaking or insanitary then answer ‘Yes’.

**5. Is the area around the storage container insanitary?**

Faeces, garbage and other wastes pose a risk to the water quality. If you see these close to the storage container, answer ‘Yes’.

**6. Do any animals have access to the area around the storage container?**

If animals can access the storage area they may pollute the area or the container with excreta. You will need to check whether animals are routinely in the area by asking residents and by personal observation in the area (including seeing any animal excreta at the site). If you observe any of these problems, answer ‘Yes’.

**7. Is the tap or utensil used to draw water from the container insanitary?**

If the tap is contaminated or, if there is no tap, the buckets, cups, ladels or other devices used to collect water may be insanitary and contamination can be introduced to the container this way. If the tap or utensils used to draw water are insanitary then answer ‘Yes’.

**8. Is the water from the container also used for washing or bathing?**

Water may be contaminated (e.g. by dirty hands) during collection for washing or bathing. Spilt bathing water may collect in the area providing an entry route for contaminants. You will need to ask residents about their practices, especially if you observe spilt water close to the container. If water is used for washing or bathing, answer ‘Yes’.

**9. Has there been discontinuity in water supply in the last 10 days?**

In addition to contamination of source water during discontinuities, during (and for a period after) discontinuities, stored water may be collected from other sources, which may be “unimproved”. You will need to ask residents about discontinuities (record the frequency and duration if this is possible). If there has been a discontinuity then answer ‘Yes’.

**10. Is the water obtained from more than one source?**

Sources may have different qualities and may not all be “improved” sources. This may be a seasonal occurrence, affected by factors such as availability of sources or the length of queues at water points. You will need to ask residents about their use of single or different sources of water (in different seasons or during discontinuities). If more than one source is used then risk-to-health information, whilst showing the risk associated with household water, cannot easily be used to inform decision makers about supply technologies. If more than one source is used, answer ‘Yes’.



**RADWQ SANITARY INSPECTION FORM**  
**HOUSEHOLD PIPED WATER**

---

**I. General information:**

- a. WSS No.: .....
- b. WSS No. of source related to household sample: .....
- c. Village/Town: .....
- d. Date of visit: .....
- e. Broad area/Region: .....
- f. Zone: .....

**II. Specific diagnostic information for assessment:**

(Please indicate at which sites the risk was identified)

**Risk**

- 1. Is the tap sited outside the house (e.g. in the yard)? Y/N
- 2. Is the water stored in a container inside the house? Y/N
- 3. Is the storage tank or any of the taps leaking or damaged? Y/N
- 4. Are any taps shared with other households? Y/N
- 5. Is the area around the tank or tap insanitary? Y/N
- 6. Are there any leaks in the household pipes? Y/N
- 7. Do animals have access to the area around the pipe? Y/N
- 8. Have users reported pipe breaks in the last week? Y/N
- 9. Has there been discontinuity in water supply in the last 10 days? Y/N
- 10. Is the water obtained from more than one source? Y/N

**Total score of risks: ...../10**

**III Results and comments:**

a. Sanitary inspection risk score (tick appropriate box):

9-10 = Very high	6-8 = High	3-5 = Medium	0-2 = Low

b. The following important points of risk were noted:

- List nos. 1-10
- Additional comments (continue on back of form if necessary)

c. *Does the distribution system deliver water directly to a storage tank (usually on/in the roof?)*

**IV Name and signature of assessors:**

## EXPLANATORY NOTES

### HOUSEHOLD PIPED WATER

---

**1. Is the tap sited outside the house (e.g. in the yard)?**

Taps in yards may be more prone to damage, especially if animals have access to the yard (see question 7). The sanitary state of the yard could also affect the risk to water quality (see question 5). If the tap is in the yard then answer ‘Yes’.

**2. Is the water stored in a container inside the house?**

There is the risk of contamination during and post-collection from the tap, e.g. from hands or from use of an insanitary container (see separate sanitary inspection form for household containers). If a container is used, answer ‘Yes’.

**3. Is the storage tank or any of the taps leaking or damaged?**

If the storage tank or taps are leaking or damaged then cracks may provide a route for contaminants to enter the pipes. You will need to differentiate between water from leaking taps and spilt water. If water from the distribution system goes directly to a storage tank (usually on/in the roof space) then record this in Section III of the sanitary inspection form. If you observe leaks or damage at the tank or any of the taps then answer ‘Yes’.

**4. Are any taps shared with other households?**

Shared facilities may not be well maintained as no-one has independent ownership and, therefore, responsibility. If taps are shared, answer ‘Yes’.

**5. Is the area around the tank or tap insanitary?**

Faeces, garbage and other wastes pose a risk to the water quality. If you see these close to the tank or any of the taps, answer ‘Yes’.

**6. Are there any leaks in the household pipes?**

You will need to observe visible pipes and check with the householder about other possible leaks. If you observe any leaks, answer ‘Yes’.

**7. Do animals have access to the area around the pipe?**

If animals can access the pipe they may cause damage to the structure as well as pollute the area with excreta. You will need to check whether animals are routinely in the area by asking residents and by personal observation in the area (including seeing any animal excreta at the site). If you observe any of these problems, answer ‘Yes’.

**8. Have users reported pipe breaks in the last week?**

Pipe breaks (or major leaks) pose a risk to water quality as contaminants can enter the system through the break. You will need to ask residents about any pipe breaks. You could also check on whether the system was disinfected after the break was mended. If breaks are reported, answer ‘Yes’.

**9. Has there been discontinuity in water supply in the last 10 days?**

During discontinuities the distribution pipes become empty and pressure differences may lead to ingress of water (and silt) from the soil around the pipes. The soil may be contaminated posing a risk to water quality. You will need to ask residents about discontinuities (record the frequency and duration if this is possible). If there has been a discontinuity then answer ‘Yes’.

**10. Is the water obtained from more than one source?**

Sources may have different qualities and may not all be “improved” sources. If more than one source is used then risk-to-health information, whilst showing the risk associated with household water, cannot easily be used to inform decision makers about supply technologies. If >1 source is used then answer ‘Yes’.

**RADWQ SANITARY INSPECTION FORM**  
**PROTECTED SPRING**

---

**I. General information:**

- a. WSS No.: .....
- b. Village/Town: .....
- c. Date of visit: .....
- d. Broad area/Region: .....
- e. People served: .....

**II. Specific diagnostic information for assessment:**

(Please indicate at which sites the risk was identified)

**Risk**

- 1. Is the collection or spring box absent or faulty? Y/N
- 2. Is the masonry or backfill area protecting the spring faulty or eroded? Y/N
- 3. If there is a spring box, is there an unsanitary inspection cover or air vent? Y/N
- 4. Does spilt water flood the collection area (e.g. from overflow pipe)? Y/N
- 5. Is the fence absent or faulty? Y/N
- 6. Can animals have access within 10 m of the spring? Y/N
- 7. Is there a latrine uphill and/or within 30 m of the spring? Y/N
- 8. Does surface water collect uphill of the spring within 30 m? Y/N
- 9. Is the diversion ditch above the spring absent or non-functional? Y/N
- 10. Are there any other sources of pollution uphill of the spring (e.g. faeces, or solid waste)? Y/N

**Total score of risks: ...../10**

**III Results and comments:**

a. Sanitary inspection risk score (tick appropriate box):

9-10 = Very high	6-8 = High	3-5 = Medium	0-2 = Low

b. The following important points of risk were noted:

- List nos. 1-10
- Additional comments (continue on back of form if necessary)

c. *Indicate if the spring is not protected!*

**IV Name and signature of assessors:**

## EXPLANATORY NOTES PROTECTED SPRING

---

### **1. Is the collection or spring box absent or faulty?**

The box helps to protect the water from contamination by surface run-off so if it is absent or faulty there is a risk to water quality. If absent or faulty, answer 'Yes'.

### **2. Is the masonry or backfill area protecting the spring faulty or eroded?**

The masonry diverts surface run-off away from the spring box, protecting the source from contamination. The backfill area, as well as helping with diversion of run-off, protects the masonry. If it is absent or eroded the risk to water quality is increased. If any of this situation is observed, answer 'Yes'.

### **3. If there is a spring box, is there an unsanitary inspection cover or air vent?**

If either the inspection cover is insanitary (or absent) or the air vent (if present) is insanitary pollutants may enter the box and contaminate the water source. If this situation is observed, answer 'Yes'.

### **4. Does spilt water flood the collection area (e.g. from overflow pipe)?**

Any spilt water may be contaminated by run-off (especially if animals have access) and, in cases of extreme flooding, may provide a route for contaminants to flow into the box. Containers may also be contaminated by the spilt water during collection. Collection of spilt water in the area also indicates that drainage or the overflow pipe is inadequate. If spilt water collection is observed, answer 'Yes'.

### **5. Is the fence absent or faulty?**

If there is no fence (or the fence is damaged) then animals can access the borehole site and may damage the structure as well as pollute the area with excreta. You will need to check the protection of the site as well as check whether animals are routinely in the area. If you observe either of these problems, answer 'Yes'.

### **6. Can animals have access within 10 m of the spring?**

If animals can access the spring site they may damage the structure as well as pollute the area with excreta. You will need to check the protection of the site as well as check whether animals are routinely in the area. If you observe any of these problems, answer 'Yes'.

### **7. Is there a latrine uphill and/or within 30 m of the spring?**

Pollution on higher ground poses a risk, especially in the wet season, as faecal material (and other pollutants) may flow into the water source posing a risk (which is increased if no surface water diversion is present). Groundwater may also flow towards the spring from the direction of the latrine. If you find this contamination risk present within 30 m of the spring, answer 'Yes'.

### **8. Does surface water collect uphill of the spring within 30 m?**

Surface water can be contaminated by dirt, garbage and faeces (especially if animals have access to the area) and, when it flows down towards the spring, may pollute the source. If the volume of collected water is high and it is suddenly released it may flow over the diversion ditch and contaminate the source. If this is seen within 30 m of the spring, answer 'Yes'.

### **9. Is the diversion ditch above the spring absent or non-functional?**

The role of the ditch is to protect the source from possibly polluted run-off by directing it away from and downhill of the box. If the ditch is filled with waste or is poorly contoured then run-off could collect and infiltrate the source posing a risk to water quality. You should look for water or waste collected in the ditch. If the ditch is absent or not functioning correctly, answer 'Yes'.

### **10. Are there any other sources of pollution uphill of the spring (e.g. faeces, solid waste)?**

Faeces, garbage and other wastes pose a risk to water quality. If you see these uphill of the spring (and especially in the fenced area), answer 'Yes'.

**RADWQ SANITARY INSPECTION FORM**  
**BOREHOLE WITH MECHANISED PUMPING**

---

**I. General information:**

- a. WSS No.: .....
- b. Village/Town: .....
- c. Date of visit: .....
- d. Broad area/Region: .....
- e. People served: .....

**II. Specific diagnostic information for assessment:**

(Please indicate at which sites the risk was identified)

**Risk**

- 1. Is there a latrine or sewer within 100 m of the pumping mechanism? Y/N
- 2. Is there a latrine within 10 m of the borehole? Y/N
- 3. Is there any source of other pollution within 50 m of the borehole (e.g. animal breeding, cultivation, roads, industry etc.)? Y/N
- 4. Is there an uncapped well within 100 m? Y/N
- 5. Is the drainage channel absent or cracked, broken or in need of cleaning? Y/N
- 6. Can animals come within 50 m of the borehole? Y/N
- 7. Is the base of the pumping mechanism permeable to water? Y/N
- 8. Is there any stagnant water within 2 m of the pumping mechanism? Y/N
- 9. Is the well seal insanitary? Y/N
- 10. Is the borehole cap cracked? Y/N

**Total score of risks: ...../10**

**III Results and comments:**

a. Sanitary inspection risk score (tick appropriate box):

9-10 = Very high	6-8 = High	3-5 = Medium	0-2 = Low

b. The following important points of risk were noted:

- List nos. 1-10
- Additional comments (continue on back of form if necessary)

**IV Name and signature of assessors:**

**EXPLANATORY NOTES**  
**BOREHOLE WITH MECHANISED PUMPING**

---

**1. Is there a latrine or sewer within 100 m of the pumping mechanism?**

Any leaks from the sewer or infiltration from the latrine could contaminate the borehole water by draw down caused by pumping. You can observe latrines and cross-check with residents but you may need to ask relevant professionals about the location of sewers. If you observe any latrines or sewers this close to the pumping mechanism, answer 'Yes'.

**2. Is there a latrine within 10 m of the borehole?**

Latrines close to groundwater supplies may affect water quality (e.g. by infiltration). You may need to visually check structures to see if they are latrines in addition to asking residents. If you observe any latrines this close to the borehole, answer 'Yes'.

**3. Is there any source of other pollution within 50 m of the borehole (e.g. animal breeding, cultivation, roads, industry etc.)?**

Animal or human faeces on the ground close to the borehole constitute a serious risk to water quality, especially when water diversion ditches are not present. Disposal of other waste (household, agricultural etc.) indicates environmental sanitation practices are poor, which constitutes a risk to water quality. This can be corroborated by observation of the general surroundings in the community where you are collecting the water sample(s). If you find any of these practices within 50 m, answer 'Yes'.

**4. Is there an uncapped well within 100 m?**

Uncapped wells can be easily contaminated and the pollution spread through the aquifer. You can check visually for such wells and also ask residents. If there are any uncapped wells in the area, answer 'Yes'.

**5. Is the drainage channel absent or cracked, broken or in need of cleaning?**

Poor construction or maintenance of the drainage channel, leading to cracks or breaks, especially when combined with spillage of water and poor sanitary conditions, poses a high risk to water quality. If you observe any of these problems, answer 'Yes'.

**6. Can animals come within 50 m of the borehole?**

If there is no fence (or the fence is damaged) then animals can access the borehole site and may damage the structure as well as pollute the area with excreta. You will need to check the protection of the site as well as check whether animals are routinely in the area (sometimes animals are kept in the fenced area for security purposes). If you observe any of these problems within 50 m, answer 'Yes'.

**7. Is the base of the pumping mechanism permeable to water?**

If the base is permeable (e.g. there is no cover or the cover has deep cracks) any surface run-off could provide a route for contamination to enter the water source. If this is observed, answer 'Yes'.

**8. Is there any stagnant water within 2 m of the pumping mechanism?**

If pools of water collect around the pumping mechanism they may provide a route for contaminants to enter the source. If you observe spilt water or pools of water close to the mechanism then answer 'Yes'.

**9. Is the well seal insanitary?**

Faeces, garbage and other wastes around the well seal pose a risk to the water quality. If you see these close to the seal, answer 'Yes'.

**10. Is the borehole cap cracked?**

Cracks allow contaminants to enter the borehole posing a risk to water quality. If deep cracks that penetrate the cap (i.e. not just superficial ones) are found then answer 'Yes'.

**RADWQ SANITARY INSPECTION FORM**  
**BOREHOLE WITH HANDPUMP**

---

**I. General information:**

- a. WSS No.: .....
- b. Village/Town: .....
- c. Date of visit: .....
- d. Broad area/Region: .....
- e. People served: .....

**II. Specific diagnostic information for assessment:**

(Please indicate at which sites the risk was identified)

**Risk**

- 1. Is there a latrine within 10 m of the borehole? Y/N
- 2. Is there a latrine or other source of faecal pollution uphill of the borehole? Y/N
- 3. Is there any source of other pollution within 10 m of the borehole (e.g. animal breeding, cultivation, roads, industry etc.)? Y/N
- 4. Is the drainage absent or faulty allowing ponding within 2 m of the borehole? Y/N
- 5. Is the drainage channel absent or cracked, broken or in need of cleaning? Y/N
- 6. Can animals come within 10 m of the borehole? Y/N
- 7. Is the apron less than 2 m in diameter? Y/N
- 8. Does spilt water collect in the apron area? Y/N
- 9. Is the apron or pump cover cracked or damaged? Y/N
- 10. Is the handpump loose at the point of attachment, or for rope-washer pumps, is the pump cover missing? Y/N

**Total score of risks: ...../10**

**III Results and comments:**

a. Sanitary inspection risk score (tick appropriate box):

9-10 = Very high	6-8 = High	3-5 = Medium	0-2 = Low

b. The following important points of risk were noted:

- List nos. 1-10
- Additional comments (continue on back of form if necessary)

c. *Indicate if the borehole is not protected!*

**IV Name and signature of assessors:**

**EXPLANATORY NOTES**  
**BOREHOLE WITH HANDPUMP**

---

**1. Is there a latrine within 10 m of the borehole?**

Latrines close to groundwater supplies may affect water quality (e.g. by infiltration). You may need to visually check structures to see if they are latrines in addition to asking residents. If you observe any latrines this close to the borehole, answer 'Yes'.

**2. Is there a latrine or other source of faecal pollution uphill of the borehole?**

Pollution on higher ground poses a risk, especially in the wet season, as faecal material (and other pollutants) may flow into the water source posing a risk (which is increased if no surface water diversion is present). Groundwater may also flow towards the borehole from the direction of the latrine. If you find this contamination risk present, answer 'Yes'.

**3. Is there any source of other pollution within 10 m of the borehole (e.g. animal breeding, cultivation, roads, industry etc.)?**

Animal or human faeces on the ground close to the borehole constitute a serious risk to water quality, especially when water diversion ditches are not present. Disposal of other waste (household, agricultural etc.) indicates environmental sanitation practices are poor, which constitutes a risk to water quality. This can be corroborated by observation of the general surroundings in the community where you are collecting the water sample(s). If you find any of these practices, answer 'Yes'.

**4. Is the drainage absent or faulty allowing ponding within 2 m of the borehole?**

If pools of water collect around the borehole they may provide a route for contaminants to enter the source. If you observe spilt water or pools of water close to the borehole then answer 'Yes'.

**5. Is the drainage channel absent or cracked, broken or in need of cleaning?**

Poor construction or maintenance of the drainage channel, leading to cracks or breaks, especially when combined with spillage of water and poor sanitary conditions, poses a high risk to water quality. If you observe any of these problems, answer 'Yes'.

**6. Can animals come within 10 m of the borehole?**

If there is no fence (or the fence is damaged) then animals can access the borehole site and may damage the structure as well as pollute the area with excreta. You will need to check the protection of the site as well as check whether animals are routinely in the area (sometimes animals are kept in the fenced area for security purposes). If you observe any of these problems, answer 'Yes'.

**7. Is the apron less than 2 m in diameter?**

The apron (platform) is built to prevent backflow of water into the borehole. To do this adequately it needs to be at least 2m in diameter. If it is too small, answer 'Yes'.

**8. Does spilt water collect in the apron area?**

If water does not drain away from the apron (platform) area then water (possibly carrying pollutants) could backflow into the water source. If you observe poor drainage, answer 'Yes'.

**9. Is the apron or pump cover cracked or damaged?**

Cracks, especially deep ones, in the apron or pump cover may allow backflow into the water source. If you see such cracks, answer 'Yes'.

**10. Is the handpump loose at the point of attachment, or for rope-washer pumps, is the pump cover missing?**

A loose handpump (or missing pump cover) may allow backflow of contaminated water into the water source. If the pump is not securely attached to the pump base in the apron (or the pump cover is missing), answer 'Yes'.



**RADWQ SANITARY INSPECTION FORM**  
**DUG WELL WITH HANDPUMP**

---

**I. General information:**

- a. WSS No.: .....
- b. Village/Town: .....
- c. Date of visit: .....
- d. Broad area/Region: .....
- e. People served: .....

**II. Specific diagnostic information for assessment:**

(Please indicate at which sites the risk was identified)

**Risk**

- 1. Is there a latrine within 10 m of the well? Y/N
- 2. Is the nearest latrine uphill of the well? Y/N
- 3. Is there any source of other pollution within 10 m of the well (e.g. animal breeding, cultivation, roads, industry etc.)? Y/N
- 4. Is the drainage absent or faulty allowing ponding within 3 m of the well? Y/N
- 5. Is the drainage channel absent or cracked, broken or in need of cleaning? Y/N
- 6. Is the cement or slab less than 2 m in diameter around the top of the well? Y/N
- 7. Does spilt water collect in the apron area? Y/N
- 8. Are there cracks in the cement floor or slab? Y/N
- 9. Is the handpump loose at the point of attachment, or for rope-washer pumps, is the pump cover missing? Y/N
- 10. Is the well-cover absent or insanitary? Y/N

**Total score of risks:                   ...../10**

**III Results and comments:**

a. Sanitary inspection risk score (tick appropriate box):

9-10 = Very high	6-8 = High	3-5 = Medium	0-2 = Low

b. The following important points of risk were noted:

- List nos. 1-10
- Additional comments (continue on back of form if necessary)

c. *Indicate if the dug well is not protected!*

**IV Name and signature of assessors:**

**EXPLANATORY NOTES**  
**DUG WELL WITH HANDPUMP**

---

**1. Is there a latrine within 10 m of the well?**

Latrines close to groundwater supplies may affect water quality (e.g. by infiltration). You may need to visually check structures to see if they are latrines in addition to asking residents. If you observe any latrines within 10 m to the well, answer 'Yes'.

**2. Is the nearest latrine uphill of the well?**

Pollution on higher ground poses a risk, especially in the wet season, as faecal material (and other pollutants) may flow into the water source posing a risk (which is increased if no surface water diversion is present). Groundwater may also flow towards the well from the direction of the latrine. If you find this contamination risk present, answer 'Yes'.

**3. Is there any source of other pollution within 10 m of the well (e.g. animal breeding, cultivation, roads, industry etc)?**

Animal or human faeces on the ground close to the well constitute a serious risk to water quality, especially when water diversion ditches are not present. Disposal of other waste (household, agricultural etc.) indicates environmental sanitation practices are poor, which constitutes a risk to water quality. This can be corroborated by observation of the general surroundings in the community where you are collecting the water sample(s). If you find any of these practices, answer 'Yes'.

**4. Is the drainage absent or faulty allowing ponding within 3 m of the well?**

If pools of water collect around the borehole they may provide a route for contaminants to enter the source. If you observe spilt water or pools of water close to the well then answer 'Yes'.

**5. Is the drainage channel absent or cracked, broken or in need of cleaning?**

Poor construction or maintenance of the drainage channel, leading to cracks and breaks, especially when combined with spillage of water and poor sanitary conditions, poses a high risk to water quality. If you observe any of these problems, answer 'Yes'.

**6. Is the cement or slab less than 2 m in diameter around the top of the well?**

The slab is build to prevent backflow of water into the well. To do this adequately it needs to be at least 2 m in diameter. If it is too small, answer 'Yes'.

**7. Does spilt water collect in the apron area?**

If pools of water collect around the well they may provide a route for contaminants to enter the source. If you observe spilt water or pools of water close to the apron then answer 'Yes'.

**8. Are there cracks in the cement floor or slab?**

Cracks, especially deep ones, in the cement may allow backflow into the water source. If you see deep cracks (not superficial ones), answer 'Yes'.

**9. Is the handpump loose at the point of attachment, or for rope-washer pumps, is the pump cover missing?**

A loose handpump (or missing pump cover) may allow backflow of contaminated water into the water source. If the pump is not securely attached to the pump base in the apron (or the pump cover is missing), answer 'Yes'.

**10. Is the well-cover absent or insanitary?**

Absence of a cover or an insanitary cover increases the likelihood of contamination entering the well. If this is observed, answer 'Yes'.

**RADWQ SANITARY INSPECTION FORM**  
**RAINWATER HARVESTING TANK**

---

**I. General information:**

- a. WSS No.: .....
- b. Village/Town: .....
- c. Date of visit: .....
- d. Broad area/Region: .....
- e. People served: .....

**II. Specific diagnostic information for assessment:**

(Please indicate at which sites the risk was identified)

**Risk**

- 1. Is the first flush system absent or broken? Y/N
- 2. Is rainwater collected in an open container? Y/N
- 3. Are there visible signs of contamination on the roof (e.g. faeces, dirt)? Y/N
- 4. Is the guttering that collects water dirty or blocked? Y/N
- 5. Is the top or wall of the tank cracked or damaged? Y/N
- 6. Is water collected directly from the tank (no tap on the tank)? Y/N
- 7. Is the tap leaking or damaged? Y/N
- 8. Is the concrete floor under the tap missing, broken or dirty? Y/N
- 9. Is there any source of pollution around the tank or water collection area? Y/N
- 10. Is the tank clean inside? Y/N

**Total score of risks: ...../10**

**III Results and comments:**

a. Sanitary inspection risk score (tick appropriate box):

9-10 = Very high	6-8 = High	3-5 = Medium	0-2 = Low

b. The following important points of risk were noted:

- List nos. 1-10
- Additional comments (continue on back of form if necessary)

**IV Name and signature of assessors:**

## EXPLANATORY NOTES

### RAINWATER HARVESTING TANK

---

**1. Is the first flush system absent or broken?**

Rain water harvesting tanks should have a way to flush the first water collected during a rainstorm. The first flow (especially at the end of the dry season) will contain a lot of dust, dirt and animal faeces washed from the roof, which constitutes a serious risk to water quality. If there is no first flush mechanism, or it is bypassed, answer 'Yes'.

**2. Is rainwater collected in an open container?**

Open rainwater collection tanks collect dust and dirt from the air, which is a possible risk to water quality. They also function as mosquito breeding sites, and the mosquitoes may spread dengue and malaria, which is a health risk (though not a water quality risk). If the tank is open then answer 'Yes'.

**3. Are there visible signs of contamination on the roof (e.g. faeces, dirt)?**

Water quality is at risk if the catchment is insanitary or contaminated. If you see plants, dirt, garbage or animal faeces etc. on the roof or area used for catchment, answer 'Yes'.

**4. Is the guttering that collects water dirty or blocked?**

Insanitary gutters can contaminate the water or introduce dirt into the tank in the same way the roof can. If the gutters present a sanitary risk, answer 'Yes'.

**5. Is the top or wall of the tank cracked or damaged?**

Cracks allow contaminants to reach the water stored in the tank. If deep cracks that penetrate the tank (i.e. not just superficial ones) are found, answer 'Yes'.

**6. Is water directly collected from the tank (no tap on the tank)?**

If there is no tap, buckets, cups or other devices will be used to collect water, and contamination can be introduced this way. If a tap is missing then answer 'Yes'.

**7. Is the tap leaking or damaged?**

A broken tap can become a pathway for contaminants. You will need to check that water is from a leak rather than spillage. If a broken tap is observed, answer 'Yes'.

**8. Is the concrete floor under the tap missing, broken or dirty?**

Missing or broken drainage under the tap will lead to insanitary conditions and possibly pools of water collecting, which pose a risk. In this case, answer 'Yes'.

**9. Is there any source of pollution around the tank or water collection area?**

Faeces, garbage and other wastes pose a risk to the water quality. If you see these close to the tank or by the area where water is collected, answer 'Yes'.

**10. Is the tank clean inside?**

A dirty inside is an obvious risk. If you can determine the state of the inside, and it is dirty, answer 'Yes'. If the tank is full, or you cannot look inside, do not answer this question. If you do not answer this question you should amend the total risk score.

## Rapid environmental risk assessment form

### I. General information:

- a. WSS No.: .....
- b. Village/Town: .....
- c. Date of visit: .....
- d. Broad area/Region: .....
- e. People served: .....

### II. Specific assessment information:

- Please use blank sheets to add any additional information in answering the questions.
- Where possible, indicate the location of the pollution source on a photocopy of an existing map or on a sketch map.
- Please fill in the boxes below or tick where appropriate.

<b>1. DOES THE WATER SOURCE HAVE ANY KNOWN POLLUTION PROBLEMS?</b>	YES	NO
<b>2. DOES THE WATER SOURCE HAVE ANY OF THE FOLLOWING WATER QUALITY PROBLEMS?</b>		
Colour: YES NO	Turbidity: YES NO	Coliforms: YES NO
Iron: YES NO	Algae: YES NO	
<b>3. PLEASE LIST ANY OTHER POLLUTION PROBLEMS WITH THE WATER SOURCE:</b>		

<b>4. IF THERE ARE ANY PROBLEMS, WHEN DO THEY OCCUR?</b>													
Jan	Feb	Mar	Apr	May	Jun	July	Aug	Sept	Oct	Nov	Dec		
Y/N	Y/N	Y/N	Y/N	Y/N	Y/N	Y/N	Y/N	Y/N	Y/N	Y/N	Y/N	Y/N	<b>COLOUR</b>
Y/N	Y/N	Y/N	Y/N	Y/N	Y/N	Y/N	Y/N	Y/N	Y/N	Y/N	Y/N	Y/N	<b>TURBIDITY</b>
Y/N	Y/N	Y/N	Y/N	Y/N	Y/N	Y/N	Y/N	Y/N	Y/N	Y/N	Y/N	Y/N	<b>COLIFORMS</b>
Y/N	Y/N	Y/N	Y/N	Y/N	Y/N	Y/N	Y/N	Y/N	Y/N	Y/N	Y/N	Y/N	<b>IRON</b>
Y/N	Y/N	Y/N	Y/N	Y/N	Y/N	Y/N	Y/N	Y/N	Y/N	Y/N	Y/N	Y/N	<b>ALGAE</b>
<b>5. FOR EACH OF THE FOLLOWING <u>POTENTIAL</u> SOURCES OF POLLUTION INDICATE WHETHER IT IS PRESENT (YES/NO) AND HOW FAR IT IS FROM THE WATER SOURCE</b>													
Potential source of pollution (S: Short term; L: Long term)		Duration		Distance from source									
		S	L	<50 m	<500 m	<1 km	<5 km						
<b>Residential:</b>													
Settlement (town/village/encroachment)													
Construction													
<b>Agricultural activity:</b>													
Livestock													
Crops													

Chemical storage						
Aquaculture						
<b>Industrial activity:</b>						
Food processing						
Textile						
Tannery						
Brewery						
Oil/petroleum (including garages)						
Abattoir (slaughter house)						
Mining						
<b>Miscellaneous:</b>						
Deforestation						
Erosion						
Other (specify)						

## Annex 3

### Quality control procedures

- Weekly record sheet for parameter quality control readings
- Control table for microbial tests
- Aseptic technique's checklist
- Aseptic technique evaluation form

### Weekly record sheet for parameter quality control readings

<b>Week (date)</b>	...	<b>Team</b>	...
--------------------	-----	-------------	-----

Parameter	Day	Units	WSS-No. of source related to quality control measurement	Quality control reading	Name of analyst
Thermotolerant coliforms	Mon	TTC/100 ml	...	...	
Thermotolerant coliforms	Tue	TTC/100 ml	...	...	
Thermotolerant coliforms	Wed	TTC/100 ml	...	...	
Thermotolerant coliforms	Thu	TTC/100 ml	...	...	
Thermotolerant coliforms	Fri	TTC/100 ml	...	...	
pH	Once a week	pH units	...	...	
Conductivity		mS/cm	...	...	
Turbidity		NTU	...	...	
Free chlorine		mg/l	...	...	
Nitrate		mg NO <sub>3</sub> /l	...	...	
Arsenic		mg/l	...	...	
Iron		mg/l	...	...	
Fluoride		mg/l	...	...	
...		mg/l	...	...	

### Control table for microbial tests (95% confidence interval counts 0-100)

Count 1	Count 2	Count 1	Count 2	Count 1	Count 2
0	0-5	34	19-53	68	47-93
1	0-7	35	20-54	69	47-95
2	0-9	36	21-55	70	48-96
3	0-11	37	22-56	71	49-97
4	0-12	38	22-58	72	50-98
5	0-14	39	23-59	73	51-99
6	1-16	40	24-60	74	52-100
7	1-17	41	25-61	75	52-102
8	2-19	42	26-63	76	53-103
9	2-20	43	26-64	77	54-104
10	3-22	44	27-65	78	55-105
11	3-23	45	28-66	79	56-106
12	4-24	46	29-67	80	57-107
13	5-26	47	29-69	81	58-108
14	5-27	48	30-70	82	58-110
15	6-28	49	31-71	83	59-111
16	6-30	50	32-72	84	60-112
17	7-31	51	33-73	85	61-113
18	8-32	52	33-75	86	62-114
19	8-34	53	34-76	87	63-115
20	9-35	54	35-77	88	63-117
21	10-36	55	36-78	89	64-118
22	10-38	56	37-79	90	65-119
23	11-39	57	38-80	91	66-120
24	12-40	58	38-82	92	67-121
25	13-41	59	39-83	93	68-122
26	13-43	60	40-84	94	69-123
27	14-44	61	41-85	95	69-125
28	15-45	62	42-86	96	70-126
29	16-47	63	42-88	97	71-127
30	16-48	64	43-89	98	72-128
31	17-49	65	44-90	99	73-129
32	18-50	66	45-91	100	74-130
33	19-52	67	46-92		



## Aseptic technique checklist

### *General hygiene:*

- All components of the field kit need to be kept away from dirt and other contamination such as
  - a. All areas in direct contact with water sample (i.e. internal surface of sample cup, internal surface of filter funnel, upper part of filtration base, surface of disc)
  - b. Surfaces in contact with the culture medium (i.e. internal surface of Petri dishes and absorbent pads)
  - c. Parts in contact with membrane filters (i.e. filtration apparatus, absorbent pads and tweezers)
- Before handling a membrane filter, the tips of tweezers should be flamed with a cigarette lighter for five seconds; allow them to cool before handling a filter
- Pad dispenser needs to be kept sterile

### *Sterilisation of the filtration apparatus:*

- Sample cup and filtration apparatus must be sterilised before use and re-sterilised between samples
- Use of methanol for sterilisation:
  - a. Disinfectant is formaldehyde gas produced as by-product of combustion in low oxygen atmosphere
  - b. Dry sample cup and filtration assembly with clean dry towel
  - c. Pour about 1 ml of methanol in sample cup
  - d. Ignite methanol with a cigarette lighter
  - e. Allow methanol to burn for several seconds, place the filtration head over the sample cup, push firmly and form good seal
  - f. Keep the filtration apparatus sealed for at least 15 minutes
- Alternatively: Immerse filtration apparatus in boiling water for ten minutes

### *Sterilisation of Petri dishes:*

- Wash dishes in a solution of mild detergent, rinse thoroughly with clean water, dry and assemble dishes
- Sterilise Petri dishes by
  - a. Placing them into an autoclave, steam steriliser or household pressure cooker at 121°C for 15 minutes; or
  - b. Placing them in conventional oven at 180°C for 30 minutes; or
  - c. Plunging bases and lids of dishes into boiling water for 10 minutes, pouring away water and assembling dishes as they dry but they are still hot

## Aseptic technique evaluation form

<b>Week (date)</b>	...	<b>Team</b>	...
--------------------	-----	-------------	-----

<b>Quality control factors</b>	<b>Assessment</b>	<b>Comments</b>
Was the kit and apparatus clean (including incubator)?	Yes No	...
Is the media stored in a dark and preferably cool place?	Yes No	...
Was the media fresh and uncontaminated?	Yes No	...
Was the pad placed in the Petri dish correctly?	Plates: Fail:	...
If pad not successfully placed in dish, did staff member use sterilised forceps to replace pad?	Plates: Fail:	...
Was the filtration apparatus and sample cup sterilised before each analysis and was this done correctly?	Tests: Fail:	...
Was the filtration and sample cup left for 15 minutes after sterilisation?	Tests: Fail:	...
Were forceps sterilised before each use, including if touched?	Tests: Fail:	...
Are forceps kept away from contamination when in use?	Tests: Fail:	...
Were filters sealed before use?	Tests: Fail:	...
Was the filter touched by staff member?	Tests: Fail:	...
Was the filter laid on the pad correctly?	Tests: Fail:	...
Was the sample cup rinsed before sample taken?	Tests: Fail:	...
Did staff member only read the yellow colonies on filter?	Plates: Fail:	...
Did staff member correctly state the number of coliforms per 100 ml?	Plates: Fail:	...

## Annex 4

### Field data daily reporting form

<i>GENERAL INFORMATION</i>			
<b>WSS-No.</b>	...	<b>Date</b>	...
<b>Broad area</b>	...	<b>Time</b>	...
<b>Zone/State</b>	...	<b>Village/Town</b>	...
<b>Supply Technology Category</b>		...	
<b>Description of Sampling Point Location</b>		...	

<i>ANALYTICAL RESULTS</i>			
<b>Parameter</b>	<b>Unit</b>	<b>Reading</b>	<b>Comment</b>
Appearance		...	...
Odour			
Thermotolerant coliforms	No./100 ml	...	...
Faecal streptococci	No./100 ml	...	...
pH	pH units	...	...
Conductivity	µS/cm	...	...
Turbidity	NTU	...	...
Free/Residual chlorine	mg/l	...	...
Total chlorine	mg/l	...	...
Nitrate	mg/l	...	...
Arsenic	mg/l	...	...
Iron	mg/l	...	...
Fluoride	mg/l	...	...
...	mg/l	...	...

	<b>Print name</b>	<b>Signature</b>
Analyst 1	...	...
Analyst 2	...	...

## Annex 5

---

### Example checklists for preparation of field work

#### Checklist for main equipment

- *For microbial analysis (membrane filtration method)*: membrane filtration apparatus, vacuum pump, incubator, incubator battery, incubator connection cables (car, mains), absorbent pad dispenser, Petri dishes, Petri dishes rack, manuals etc. (detailed equipment list will depend on model of field kit used)
- *For physiochemical analysis*: photometer and cells with cover, pH meter, conductivity meter and cells with cover, turbidity meter and cells with cover, manuals etc. (detailed equipment list will depend on field equipment models used)

#### Checklist for reagents and consumables

- Reagents for photometric nitrate, fluoride, chlorine, iron and arsenic analysis
- Calibration solutions for turbidity and conductivity meters
- Buffer solutions for pH meter
- For microbial analysis (membrane filtration method): media, media measuring devices, filters, absorbent pads, sterile pipettes
- Methanol for sterilisation of membrane filtration apparatus
- Denaturised alcohol for other disinfection purposes
- Deionised or distilled water (sterile)
- Lubrication grease

#### Checklist for additional equipment required when storage and transport of samples is necessary

- Sodium thiosulphate solution (0.1%)
- Sampling bottles
- Cool bag
- Ice blocks

#### Checklist for extras to main equipment and reagents

- Rucksack or equivalent
- Photocopied sanitary inspection forms
- Photocopied daily report forms
- Photocopied quality control forms
- Photocopied work plan and standard operating procedure for each parameter to be tested
- Photocopied letters from the Ministry introducing the team members to relevant local agencies/communities/house holds where samples are to be taken
- Log book

- Marker pen, normal pen, pencils
- Briefcases and clipboards
- Administrative maps
- Kerosene stove or electric kettle
- Cigarette lighter
- Digital timer
- Waste disposal plastic bags
- Disposal container/bottle for arsenic waste
- Sampling bottles for microbial analysis (sterilisable)
- Sampling bottles for physiochemical analysis
- Beakers and cylinders
- Jerry can and bowls
- Tissue paper/clean towel
- Cotton wool
- Bleach or liquid detergent
- Sponge and (bottle) brush
- Forceps and scissors
- Disposable hand gloves
- Masking tape
- Spare batteries for turbidity, conductivity and pH meters and photometer
- Plug adapter
- Extension rope

### **Morning checklist**

- Check completeness of main equipment, extra items and consumables (as listed above)
- Calibrate conductivity and pH meters every morning
- Calibrate turbidity meter every morning
- Prepare sufficient amount of media for the day's number of samples
- Prepare sufficient number of Petri dishes for the day's number of samples and dispense media pads

### **Checklist for personal comfort**

- Drinking-water
- Hat and/or umbrella (to protect from rain or sun)
- Food (biscuits)
- Stipends for feeding and accommodation during the field trip
- First aid kit

### Options for advanced statistical analysis

#### Introduction

In addition to the basic analyses described in Sections 8.3 and 8.4, more detailed statistical analysis of the data may increase the value of the results. A range of further possible analyses are discussed briefly below but, for more detailed statistical analysis, users of this handbook are encouraged to consult the text by Helsel and Hirsch (1992).

Microbial data, and some chemical data, do not follow normal distributions and will have a considerable number of outliers (i.e. very low or high values). For these reasons, it is often most useful to use non-parametric statistics. The median rather than the mean should be used as the measure of central tendency, as it the median is not affected by extreme values and is a powerful statistic commonly used in water resources and water quality data analysis. Statistical analysis using water quality data is often most effective and powerful when non-parametric tests, such as Kruskal-Wallis and Mann-Whitney U-tests are used. These show no loss of power in comparison to parametric tests. However, for data on some chemical parameters, which have few outliers, it may be possible to use parametric tests, including the mean, standard deviation, student t-test and ANOVA (analysis of variance).

#### Analysis of chemical quality data

There are a number of useful analyses that can be carried out on the chemical data collected as part of basic/initial level assessments but especially for data from higher level assessments. The selection of correct and useful tests is partly dependent on the nature of the data, but most analyses are likely to be comparisons between mean or median concentrations of different groups.

The data may be used to

- compare individual parameters between technologies, regions, urban and rural areas to identify if there are particular technologies or regions that have specific water quality problems;
- compare water sources (e.g. deep groundwater, surface water, aquifers) and shallow and deep groundwater to assess whether shifts in source use or changes in treatments are required;
- investigate whether concentrations of nitrate are greater in sources in urban areas or rural areas to help define whether nitrate derives from sanitation and/or fertilisers;
- assess correlation between parameters, for instance arsenic and iron and possibly arsenic and fluoride to assess whether there is a co-association and therefore the possibility that multiple health risks may occur; and
- compare nitrate to the microbial data (nitrate is the only suitable basic/initial RADWQ parameter for such comparison), however, care would be needed when interpreting such data as nitrate alone cannot act as a proxy for microbial quality;
- compare nitrate and chloride data to see whether nitrate is likely to derive from faecal or non-faecal sources

In higher level assessments where quantities of data are greater, it may also be possible to determine (over all technologies) whether proxy parameters are of value or significance, including comparisons of

- turbidity against thermotolerant coliform counts (possibly using Spearman and/or t-test);
- conductivity against nitrate, fluoride and/or arsenic (possibly using Spearman and/or t-test)

Statistical analysis of the chemical and sanitary inspection data is unlikely to be useful as the sanitary inspections are designed to identify primarily risks that would lead to microbial contamination and would not cover all environmental aspects of relevance for chemical contamination. The greater range of data collected in higher level assessments lends itself to further detailed analysis, particularly in combination with the data from catchment and hydrogeological assessments, treatment audits and hazard analyses. In these higher level assessments, provided that data on chloride are collected, an analysis of the nitrate-chloride-ratio is a useful tool in determining whether the nitrate is derived from faecal matter or other sources.

### Analysis of microbial and sanitary risk data

To obtain results that have statistical significance, two types of analysis are recommended: use of contingency tables or logistic regression models. Data analysis by contingency tables is very useful when testing the statistical significance of associations between the presence of sanitary risk factors and exceeding a water quality target. Regression models are useful when trying to model the influence of multiple factors on an outcome. Such analyses are effective tools for data analysis and interpretation and relatively easy to perform if statistical software (such as SPSS, Stata and Minitab) is available. Although it is possible to do this type of analysis without computer software, such an approach is not described here.

To undertake the analysis, the microbial quality data should be transformed into binomial data. This means it is converted into data using questions that can only be answered with either “yes” or “no” – for instance, if a water quality target is exceeded then the data will be converted into a “yes” and if the water quality target is met the answer is “no”. This is the same type of data as the data on individual sanitary risk factors. As the analysis that follows requires numerical data, the binomial data must be dummy-coded, that is a numerical value is assigned. For the analysis with sanitary inspection data, it is most convenient to code the “yes”-answers as 1 and the “no”-answers as 0. This is because the presence of a risk factor should, in principle, be related to the exceeding of a water quality target.

In contingency tables, the statistics most commonly used are odds ratios, which for binomial data is the ratio of the probability of obtaining a score of 1 divided by the probability of obtaining a score of 0. An odds ratio exceeding 1 indicates that a positive relationship exists between the factor and the outcome whereas a score of less than one indicates that a negative relationship exists. An example of a contingency table is shown in Table A.1. In this table, p is the significance of the odds ratio calculated and the 95% confidence interval (CI) column refers to the range of values lying with the upper and lower bound estimates of the 95% confidence level.

**Table A.1: Contingency table analysis**

Risk factors	Exceeding water quality target of < 10 TTC/100 ml		
	Odds ratio	p	95% CI
Faulty masonry	1.29	0.278	0.81-2.06
Backfill area eroded	2.51	<0.001	1.56-4.06
Collection area floods	0.97	0.905	0.59-1.60
Fence absent or faulty	2.96	0.039	1.05-8.29
Animal access < 10 m	1.96	0.184	0.73-5.31
Latrine < 30 m uphill of spring	1.45	0.583	0.38-5.52
Surface water uphill	1.88	0.030	1.06-3.33
Diversion ditch faulty	2.14	0.003	1.30-3.53
Other pollution uphill	1.51	0.078	0.96-2.37

Logistic regression is a statistical test that allows regression analysis of discrete data. It is a powerful tool for analysing the influence of multiple factors on an outcome or discontinuous variable in the same way as linear (multiple) regression analysis for continuous data. If this type of analysis is to be undertaken, it is recommended that readers consult statistical texts or papers that have employed such an approach, such as Howard *et al.* (2003).

### Identifying the causes of microbial contamination in piped water supplies

When using the sanitary inspection data to determine whether water quality failure relates to either local or supply risks, it is important not simply to look at microbial data but also chlorine residual levels. The effectiveness of chlorine and other disinfectants on micro-organisms in water is a function not only of the concentration of the free chlorine that causes inactivation but also of the time for which a micro-organism is exposed to the chlorine – the contact time value.

When water undergoes terminal disinfection, dosing is usually based on the chlorine demand - the chlorine required to achieve full disinfection. It is usual for chlorine residual to be maintained during distribution to ensure that protection is provided against subsequent ingress of contaminated surface or groundwater. For chlorine this is usually a minimum of 0.2 mg/l, although in some countries lower levels (such as 0.1 mg/l) are accepted. Given that disinfectants rely on both concentration and time, microbial failures may occur if the source of pollution is close to the sampling point and there is a direct entry for the pollutant into the pipe. This typically relates to stagnant water around the riser pipes or the presence of wastes either directly in contact with or very close to pipes. The free disinfectant residual in such cases is unlikely to be able to inactivate all bacteria and other microbes unless it is at a very high level (e.g. exceeding 1 mg/l for chlorine).

Similar statistical analyses as those described for point sources can be used to evaluate the influence of specific sanitary risk factors and chlorine residuals on exceeding a water quality target. It is recommended that both free and total chlorine residuals are included within the analysis, as this may provide an indication of whether low free chlorine residuals when microbial indicators are present are caused through consumption by ingress of contaminated water or whether the level of chlorine in the water was inadequate to start with. An example of a contingency table is shown in Table A.2. As for Table A.1, an odds ratio exceeding 1 indicates that a positive relationship exists between the factor and the outcome; a score of less than 1 indicates a negative relationship.

**Table A.2: Contingency table for sanitary risks in piped water supply**

Risk factor	Statistics		
	Odds Ratio	p	95%CI
Tap stands lack support	1.87	<0.001	1.17
Surface water around tap	2.98	<0.001	1.83
Area uphill of tap eroded	0.48	<0.001	0.36
Piped exposed close to tap	1.18	0.324	0.77
Human excreta < 10 m of tap	1.01	0.938	0.74
Sewer < 30 m of tap	1.00	0.998	0.83
Discontinuity < 7 days	1.12	0.585	0.90
Signs of leaks in Parish	0.86	0.359	0.26
Community report pipe break < 10 days	1.98	0.008	2.08
Main pipe exposed in Parish	2.20	<0.001	1.62
Adequate free chlorine	0.28	<0.001	0.73
Adequate total chlorine	0.21	<0.001	0.62



The advantage of this type of analysis is that other factors (for instance the nature of the organisation operating the supply) can also be incorporated into the analysis as a dummy-coded variable. This may be of value in situations where it is believed that some organisations are more effective water supply managers than others. This should be included within the data analysis and reporting where possible.

### **Suggested final report structure**

#### **1 Executive summary**

#### **2 Contents lists**

Lists of boxes, figures, photographs and tables

#### **3 Introduction**

General description of country, including urban and rural proportions of the population

Description of available water-related health statistics

Estimated numbers of people served by different technology types and current levels of access to “improved” water supply and sanitation

Breakdown of water source availability by technology type and region

#### **4 Sites surveyed**

Description of survey design

Descriptions of large areas used in survey design

Descriptions of clusters identified (including technologies found)

Map of country showing large areas and clusters

Identification of how many samples of each technology type were visited per cluster

#### **5 Water quality parameters included and means analysis**

Level of assessment undertaken

Parameters included within study, including justifications for any omissions from the core parameters and any additional parameters and for any variations in parameters analysed for in different clusters

Summary of the numbers of samples analysed for different parameters and sanitary inspections performed for each technology

Description of methods used for analysis

Quality control and assurance procedures followed

Sanitary inspection forms used

#### **6 Results**

Results of statistical data analysis for each technology type and broad area (as proposed in Chapter 8) such as

- Summaries of compliance rates for microbial, chemical and physical parameters for both source water and household water quality
- Assessment of sanitary integrity
- Relationships between water quality and sanitary risk scores
- Assessments of the relationships between particular factors and contamination
- If possible, confidence levels precisions in statistical analysis
- Brief verbal description of major findings

## **7 Discussion and implications of findings**

Discussion of results in relation to the levels of exposure to water contaminants and the implications that this may have for public health

Discussion of overall picture of water quality (i.e. microbial, chemical and physical), including differences in water quality between different areas and technology types and likely causative factors influencing water quality (e.g. aquifers, climate, management approach etc.)

Discussion of differences in the quality of water sources and household water

Discussion of sanitary status of water supplies, including implications of sanitary risk scores in relation to future trends in water quality and in relation to existing operation and maintenance programmes by technology and/or region

Discussion of findings in relation to their statistical significance

## **8 Conclusions and recommendations**

Major conclusions from the RADWQ study in relation to the safety of drinking-water

Recommendations in relation interventions required to improve/maintain water safety, including educational, environmental or engineering interventions

Recommendations in relation to further development of routine monitoring and surveillance programmes, including monitoring capacities

## **9 Annexes**

List of team members

Details on project budget

Dates and itineraries followed during field work

Details on survey design

Details on field equipment used

Record sheets used during field work

Sanitary inspection forms used during field work

